

Lecture 8: Single electron transistor

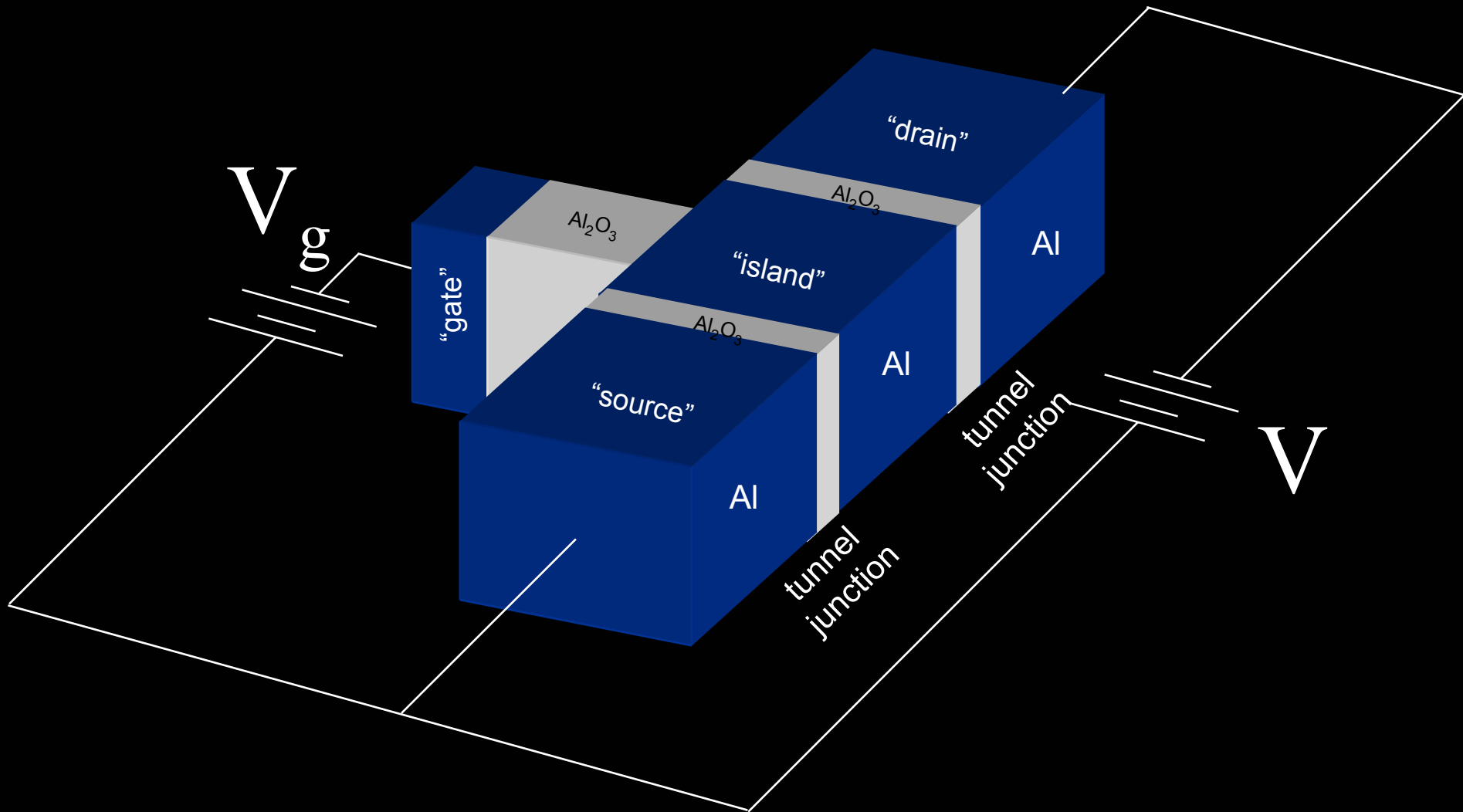

Single electron transistor circuit

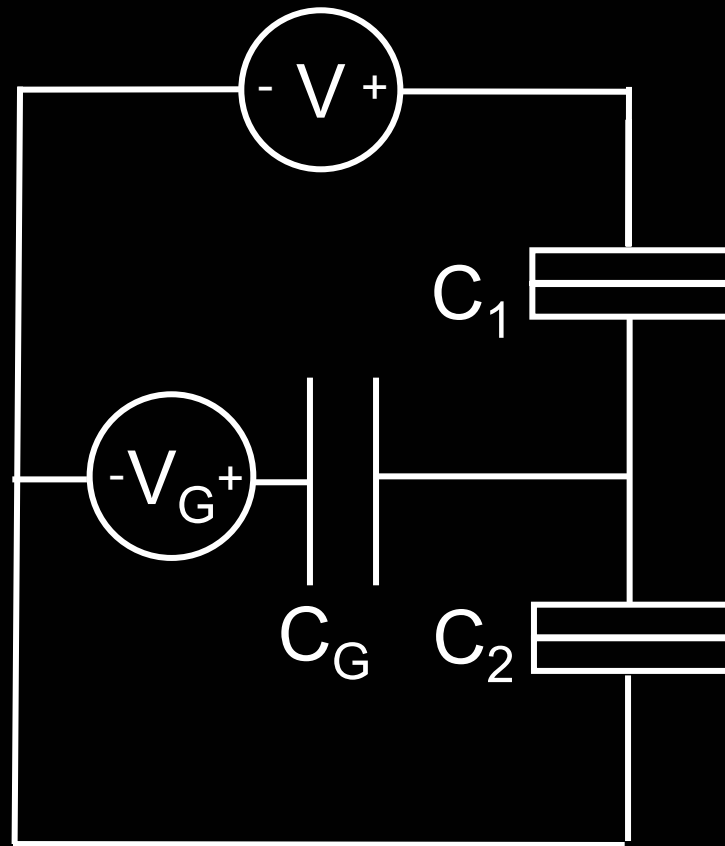

Capacitor charges

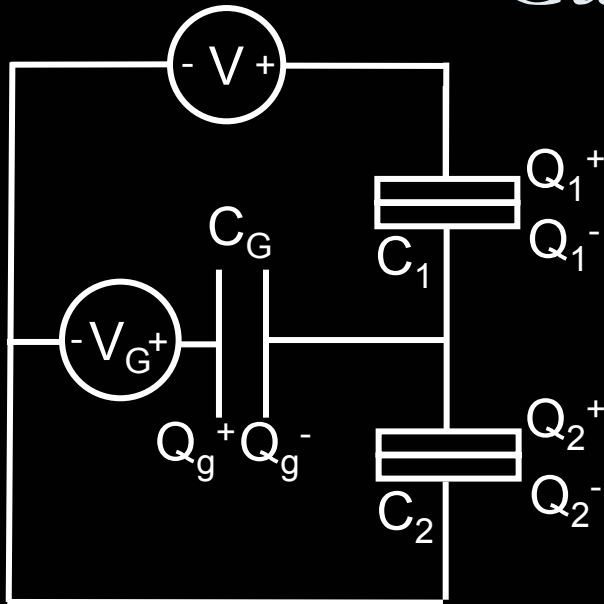

Kirchoff:

$$V = \frac{Q_1}{C_1} + \frac{Q_2}{C_2}$$

$$V_g = \frac{Q_g}{C_g} + \frac{Q_2}{C_2}$$

Island charge:

$$Q_i = Q_2 - Q_1 - Q_g$$

3 equations, 3 unknowns, solve:

$$Q_1 = \frac{C_1 V (C_2 + C_g) - C_1 C_g (Q_i + V_g)}{C_\Sigma}$$

$$C_\Sigma \equiv C_1 + C_2 + C_g$$

$$Q_2 = \frac{C_2 Q_i + C_1 C_2 V + C_g C_2 V_g}{C_\Sigma}$$

$$Q_2 = \frac{-C_g Q_i - C_1 C_g V + C_g V_g (C_1 + C_2)}{C_\Sigma}$$

Electrostatic energy

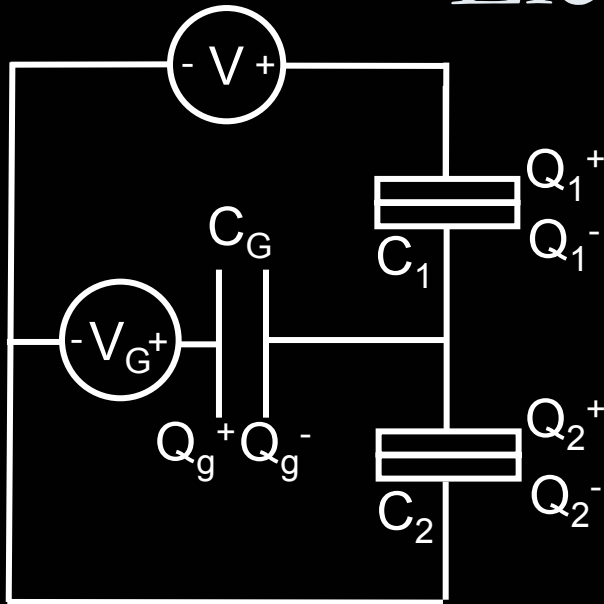

$$E = \frac{Q_1^2}{2C_1} + \frac{Q_2^2}{2C_2} + \frac{Q_G^2}{2C_G}$$

$$Q_1 = \frac{C_1 V (C_2 + C_g) - C_1 C_g V_G - C_1 Q_i}{C_\Sigma}$$

$$Q_2 = \frac{C_2 Q_i + C_1 C_2 V + C_g C_2 V_g}{C_\Sigma}$$

$$Q_G = \frac{-C_g Q_i - C_1 C_g V + C_g V_g (C_1 + C_2)}{C_\Sigma}$$

$$E = \frac{1}{2C_\Sigma} \left[C_G C_1 + (V - V_G)^2 + C_1 C_2 V^2 + C_G C_2 V_G^2 + Q_i^2 \right]$$

Free energy :

$$G = E - Q_1 V - Q_G V_G$$

Can current flow?

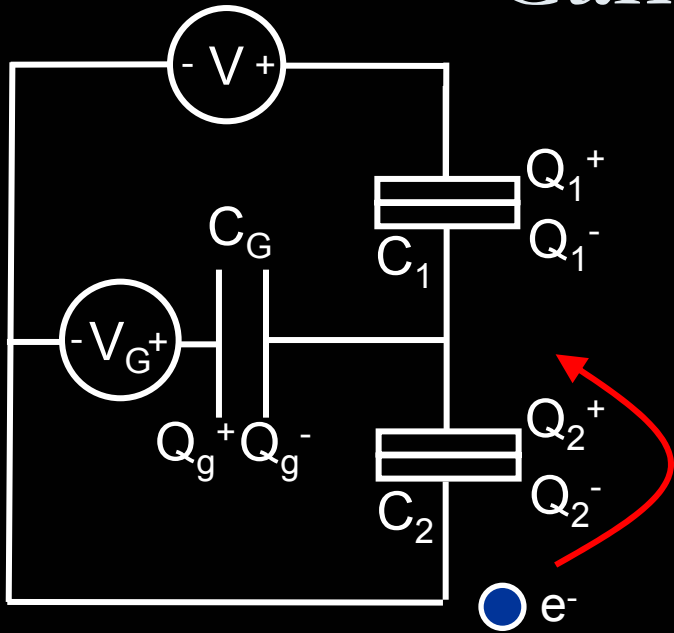

$$\Delta G = \Delta E - V \Delta Q_1 - V_G \Delta Q_G$$

Before:

$$Q_i = -n_0 e$$

After:

$$Q_i = -n_0 e - e$$

$$E = \frac{1}{2C_\Sigma} \left[C_G C_1 + (V - V_G)^2 + C_1 C_2 V^2 + C_G C_2 V_G^2 + Q_i^2 \right]$$

$$\Delta E = \frac{-2n_0 e^2 - e^2}{2C_\Sigma}$$

Can current flow?

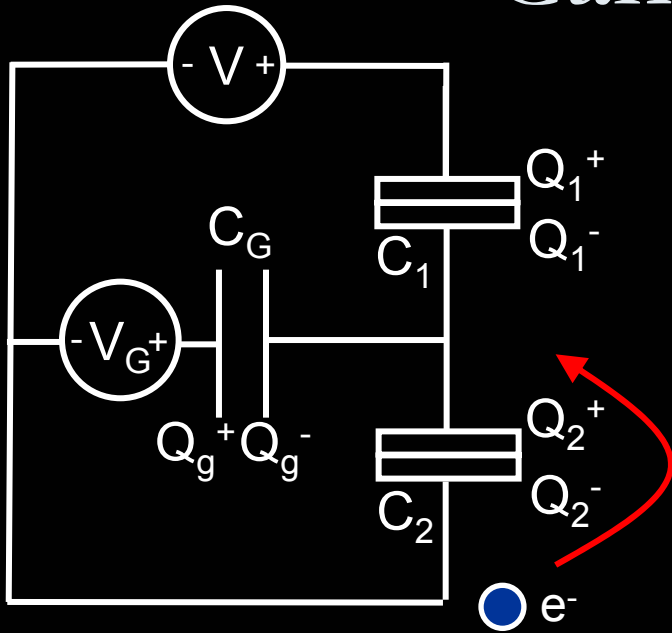

$$\Delta G = \Delta E - V \Delta Q_1 - V_G \Delta Q_G$$

Before: $Q_i = -n_0 e$

After: $Q_i = -n_0 e - e$

$$Q_1 = \frac{C_1 V (C_2 + C_g) - C_1 C_g V_G - C_1 Q_i}{C_\Sigma}$$

$$\Delta Q_1 = \Delta \frac{C_1 V (C_2 + C_g) - C_1 C_g V_G - C_1 Q_i}{C_\Sigma} = \frac{-C_1 (-n_0 e)}{C_\Sigma} - \frac{-C_1 (-n_0 e - e)}{C_\Sigma}$$

$$\Delta Q_1 = \frac{-e C_1}{C_\Sigma}$$

Can current flow?

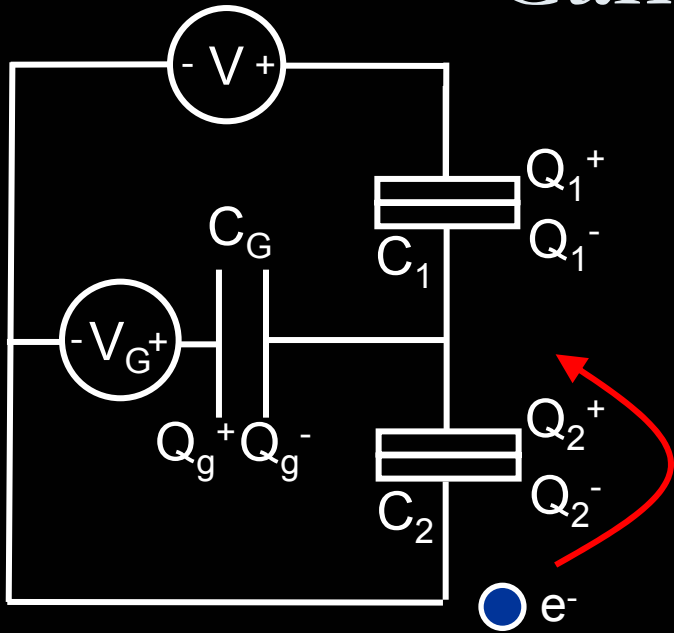

$$\Delta G = \Delta E - V \Delta Q_1 - V_G \Delta Q_G$$

Before: $Q_i = -n_0 e$

After: $Q_i = -n_0 e - e$

$$Q_G = \frac{-C_g Q_i - C_1 C_g V + C_g V_g (C_1 + C_2)}{C_\Sigma}$$

$$\Delta Q_G = \Delta \frac{-C_g Q_i - C_1 C_g V + C_g V_g (C_1 + C_2)}{C_\Sigma} = \frac{-C_g (-n_0 e)}{C_\Sigma} - \frac{-C_g (-n_0 e - e)}{C_\Sigma}$$

$$\Delta Q_G = \frac{-e C_g}{C_\Sigma}$$

Can current flow?

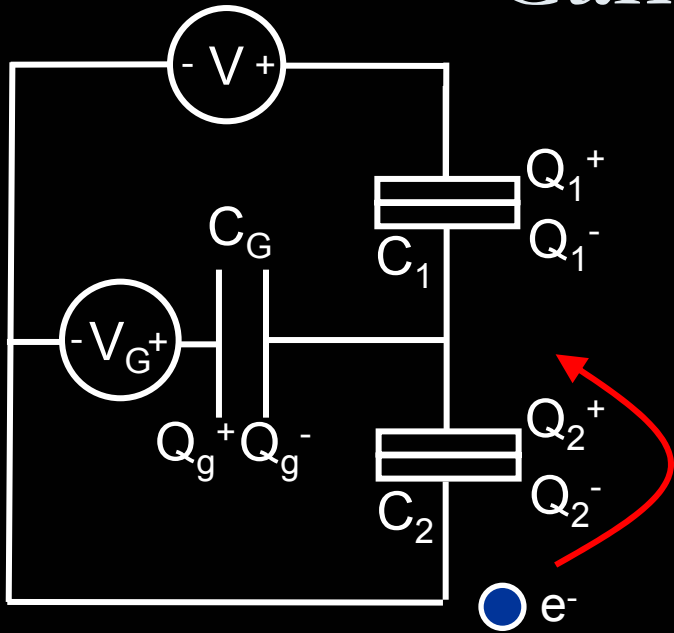

$$\Delta G = \Delta E - V \Delta Q_1 - V_G \Delta Q_G$$

$$\Delta E = \frac{-2n_0 e^2 - e^2}{2C_\Sigma}$$

$$\Delta Q_1 = \frac{-eC_1}{C_\Sigma}$$

$$\Delta Q_G = \frac{-eC_g}{C_\Sigma}$$

$$\Delta G = \frac{-2n_0 e^2 - e^2}{2C_\Sigma} + V \frac{eC_1 C_g}{C_\Sigma} + V_G \frac{eC_g}{C_\Sigma}$$

$$\Delta G = \frac{e}{C_\Sigma} \left[-n_0 e - \frac{e}{2} + C_1 V + C_g V_G \right] > 0$$

Similarly

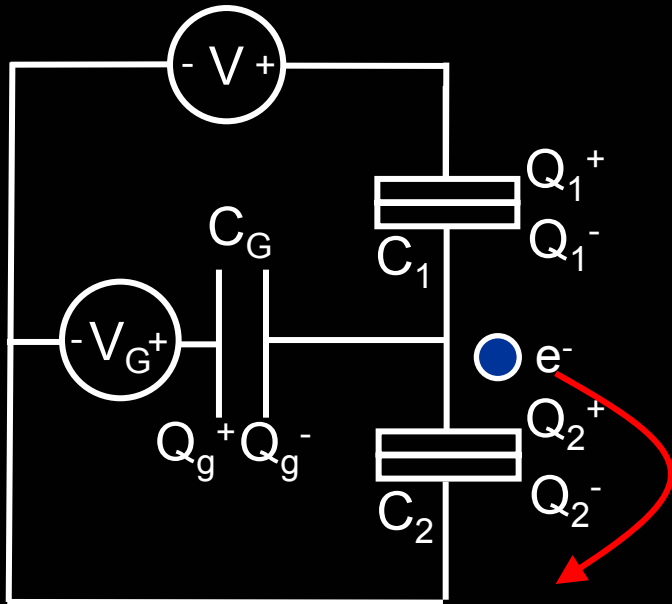

Allowed only if:

$$\Delta G = \frac{e}{C_\Sigma} \left[+n_0 e - \frac{e}{2} - C_1 V - C_g V_G \right] > 0$$

n_0 is the number of electrons on the island *before* the tunnel event.

Can current flow?

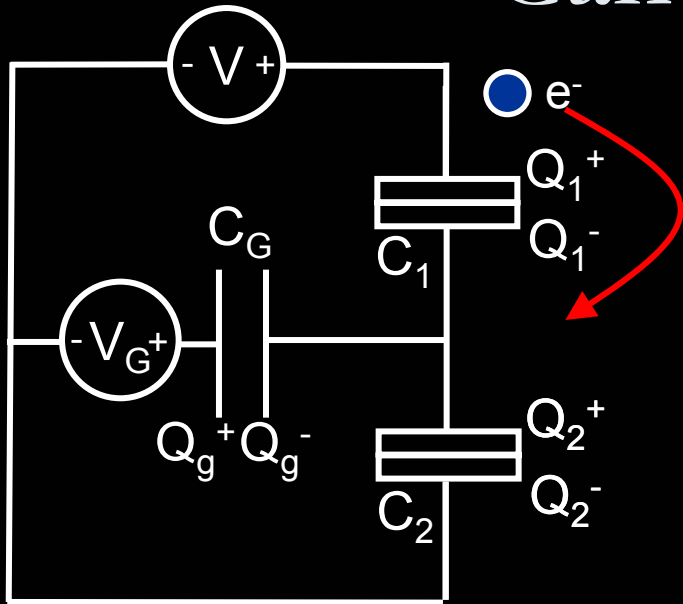

$$\Delta G = \Delta E - V \Delta Q_1 - V_G \Delta Q_G$$

Before:

$$Q_i = -n_0 e$$

After:

$$Q_i = -n_0 e + e$$

$$E = \frac{1}{2C_\Sigma} \left[C_G C_1 + (V - V_G)^2 + C_1 C_2 V^2 + C_G C_2 V_G^2 + Q_i^2 \right]$$

$$\Delta E = \frac{-2n_0 e^2 - e^2}{2C_\Sigma}$$

Can current flow?

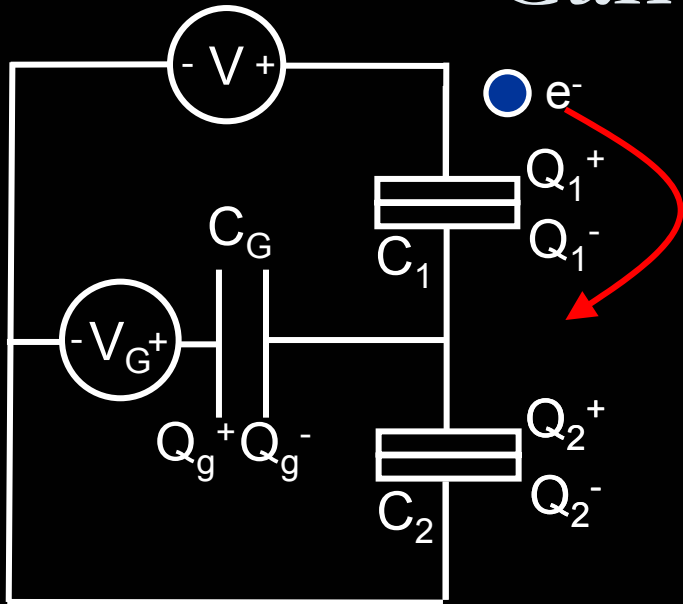

$$\Delta G = \Delta E - V \Delta Q_1 - V_G \Delta Q_G$$

Before:

$$Q_i = -n_0 e$$

After:

$$Q_i = -n_0 e + e$$

$$Q_1 = \frac{C_1 V (C_2 + C_g) - C_1 C_G V_G - C_1 Q_i}{C_\Sigma}$$

$$\Delta Q_1 = \Delta \frac{C_1 V (C_2 + C_g) - C_1 C_G V_G - C_1 Q_i}{C_\Sigma} = \frac{-C_1 (-n_0 e)}{C_\Sigma} - \frac{-C_1 (-n_0 e - e)}{C_\Sigma}$$

$$\Delta Q_{1,polarization} = \frac{-e C_1}{C_\Sigma}$$

$$\Delta Q_{1,tunnel} = e$$

$$\Delta Q_{1,total} = \Delta Q_{1,polarization} + \Delta Q_{1,tunnel} = \frac{-e C_1}{C_\Sigma} + e = \frac{-e C_1}{C_1 + C_2 + C_G} + \frac{e C_1 + e C_2 + e C_G}{C_1 + C_2 + C_G} = e \frac{C_2 + C_G}{C_\Sigma}$$

Can current flow?

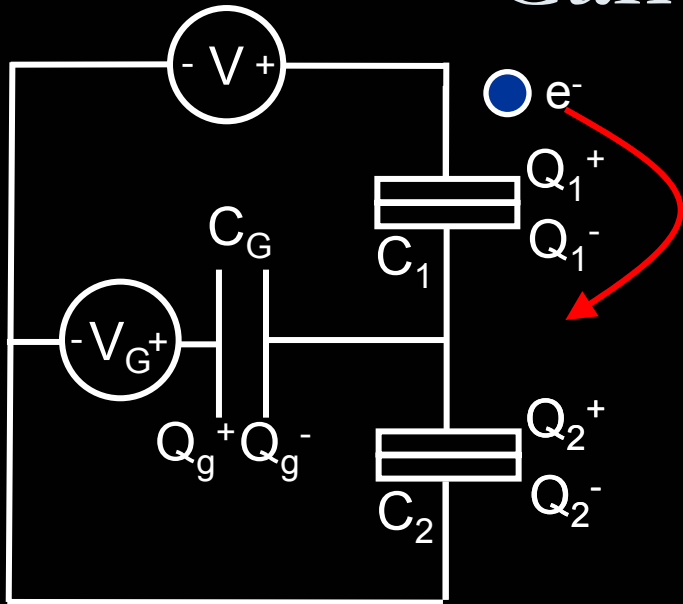

$$\Delta G = \Delta E - V \Delta Q_1 - V_G \Delta Q_G$$

Before:

$$Q_i = -n_0 e$$

After:

$$Q_i = -n_0 e + e$$

$$Q_G = \frac{-C_g Q_i - C_1 C_g V + C_g V_g (C_1 + C_2)}{C_\Sigma}$$

$$\Delta Q_G = \Delta \frac{-C_g Q_i - C_1 C_g V + C_g V_g (C_1 + C_2)}{C_\Sigma} = \frac{-C_g (-n_0 e)}{C_\Sigma} - \frac{-C_g (-n_0 e - e)}{C_\Sigma}$$

$$\Delta Q_G = \frac{-e C_g}{C_\Sigma}$$

Can current flow?

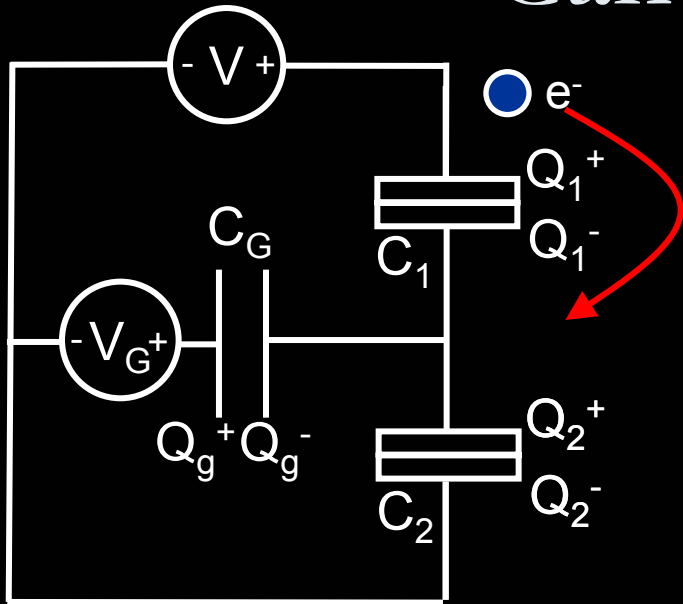

$$\Delta G = \Delta E - V \Delta Q_1 - V_G \Delta Q_G$$

$$\Delta E = \frac{-2n_0 e^2 - e^2}{2C_\Sigma}$$

$$\Delta Q_{1,total} = e \frac{C_2 + C_G}{C_\Sigma}$$

$$\Delta Q_G = \frac{-e C_g}{C_\Sigma}$$

$$\Delta G = \frac{-2n_0 e^2 - e^2}{2C_\Sigma} - V e \frac{C_2 + C_G}{C_\Sigma} + V_G \frac{e C_g}{C_\Sigma}$$

$$\Delta G = \frac{e}{C_\Sigma} \left[-n_0 e - \frac{e}{2} - V (C_2 + C_G) + V_G C_g \right] > 0$$

Similarly:

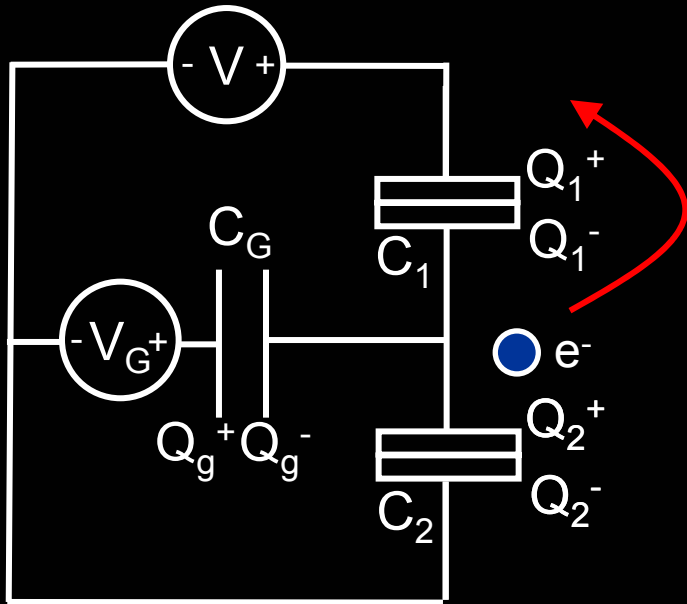

Allowed only if:

$$\Delta G = \frac{e}{C_\Sigma} \left[+n_0 e - \frac{e}{2} + V(C_2 + C_G) - V_G C_g \right] > 0$$

n_0 is the number of electrons on the island *before* the tunnel event.

Summary:

$$+n_0e - \frac{e}{2} + V(C_2 + C_G) - V_G C_g > 0$$

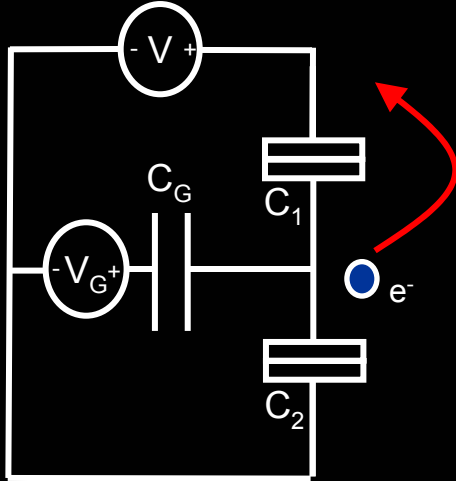

$$-n_0e - \frac{e}{2} + C_1V + C_gV_G > 0$$

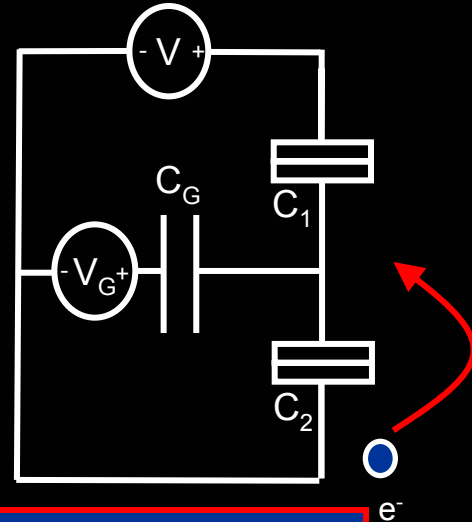

$$-n_0e - \frac{e}{2} - V(C_2 + C_G) + V_G C_g > 0$$

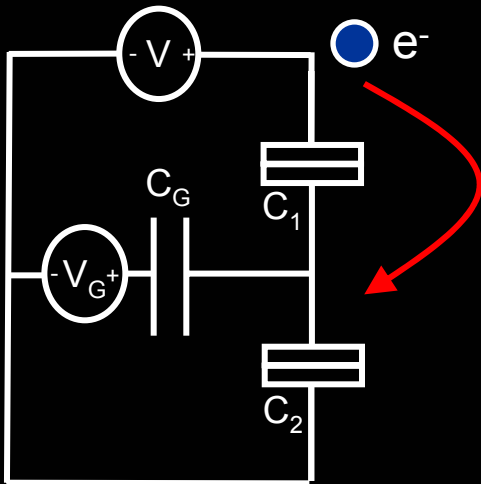

$$+n_0e - \frac{e}{2} - C_1V - C_gV_G > 0$$

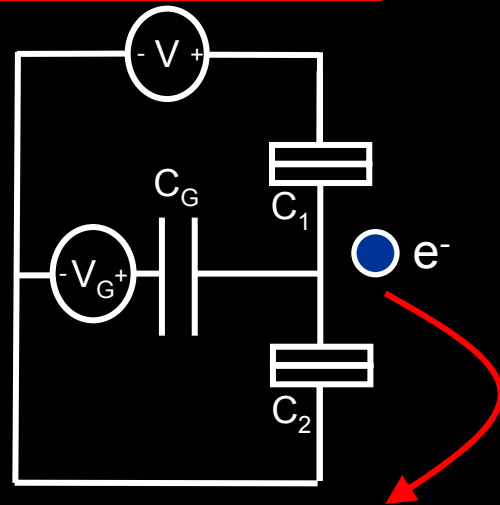

Current?

Let $n_0=0$.

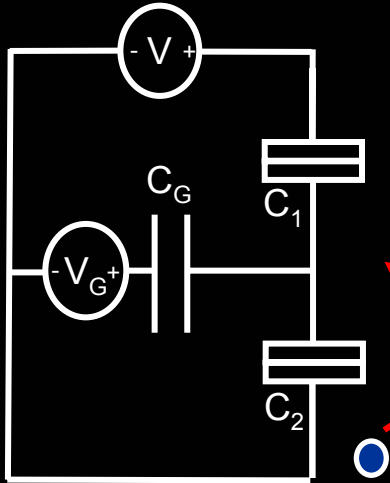

$$-\frac{e}{2} + C_1 V + C_g V_G > 0$$

$$V > \frac{e}{2C_1} - \frac{C_g}{C_1} V_G$$

Now $n_0=1$.

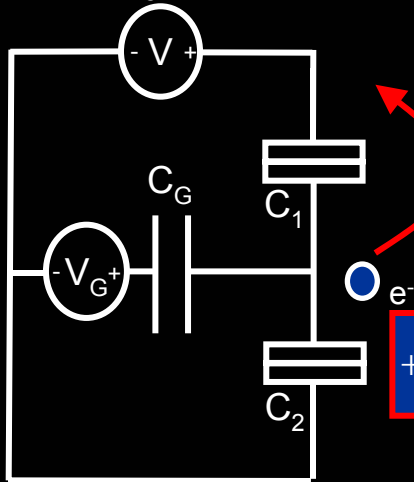

$$+\frac{e}{2} + V(C_2 + C_G) - V_G C_g > 0$$

$$V > \frac{C_g}{(C_2 + C_G)} V_G - \frac{e}{2(C_2 + C_G)}$$

Current?

$$V > \frac{e}{2C_1} - \frac{C_g}{C_1} V_G$$

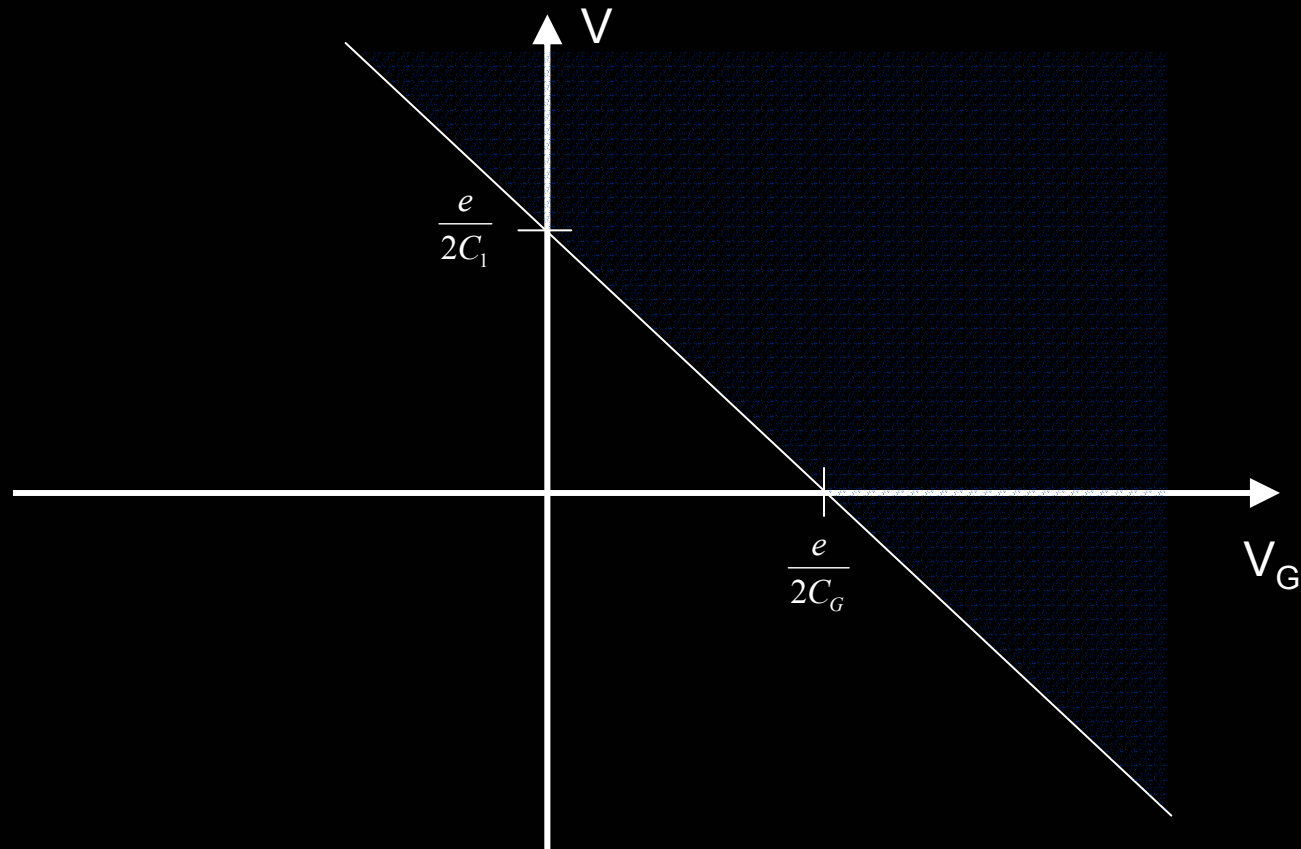

Current?

$$V > \frac{C_g}{(C_2 + C_G)} V_G - \frac{e}{2(C_2 + C_G)}$$

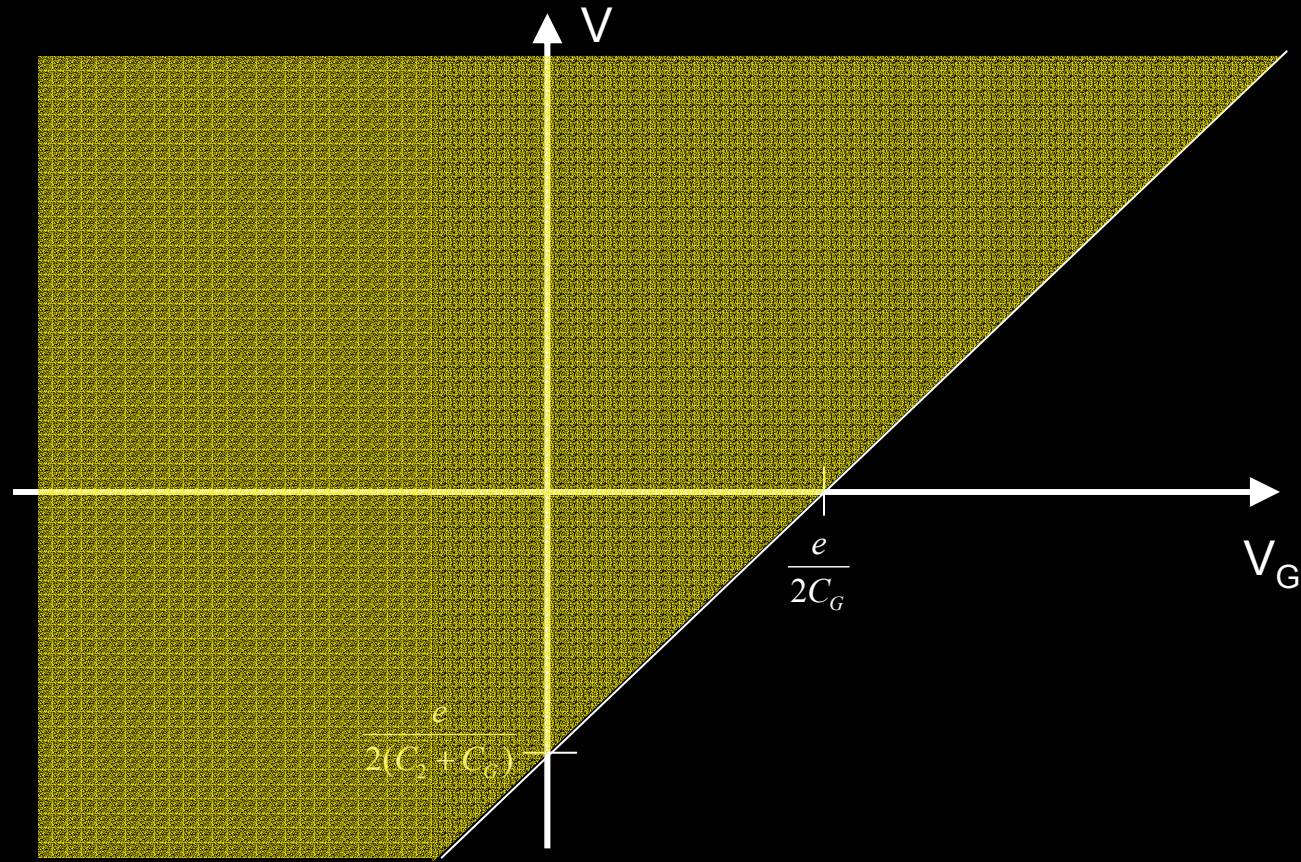

Current?

$$V > \frac{e}{2C_1} - \frac{C_g}{C_1} V_G$$

$$V > \frac{C_g}{(C_2 + C_G)} V_G - \frac{e}{2(C_2 + C_G)}$$

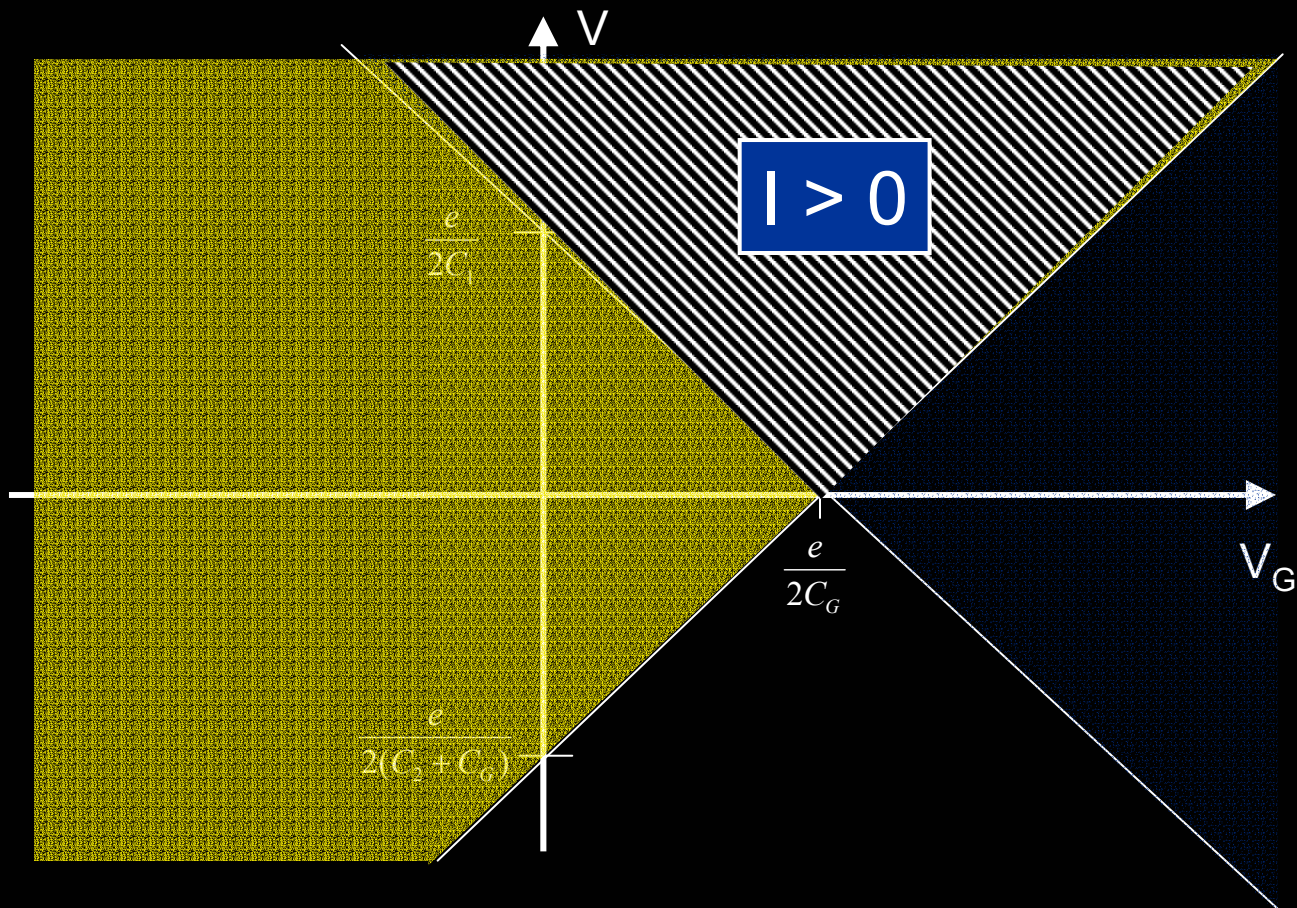

Current?

$$V > \frac{e}{2C_1} - \frac{C_g}{C_1} V_G$$

$$V > \frac{C_g}{(C_2 + C_G)} V_G - \frac{e}{2(C_2 + C_G)}$$

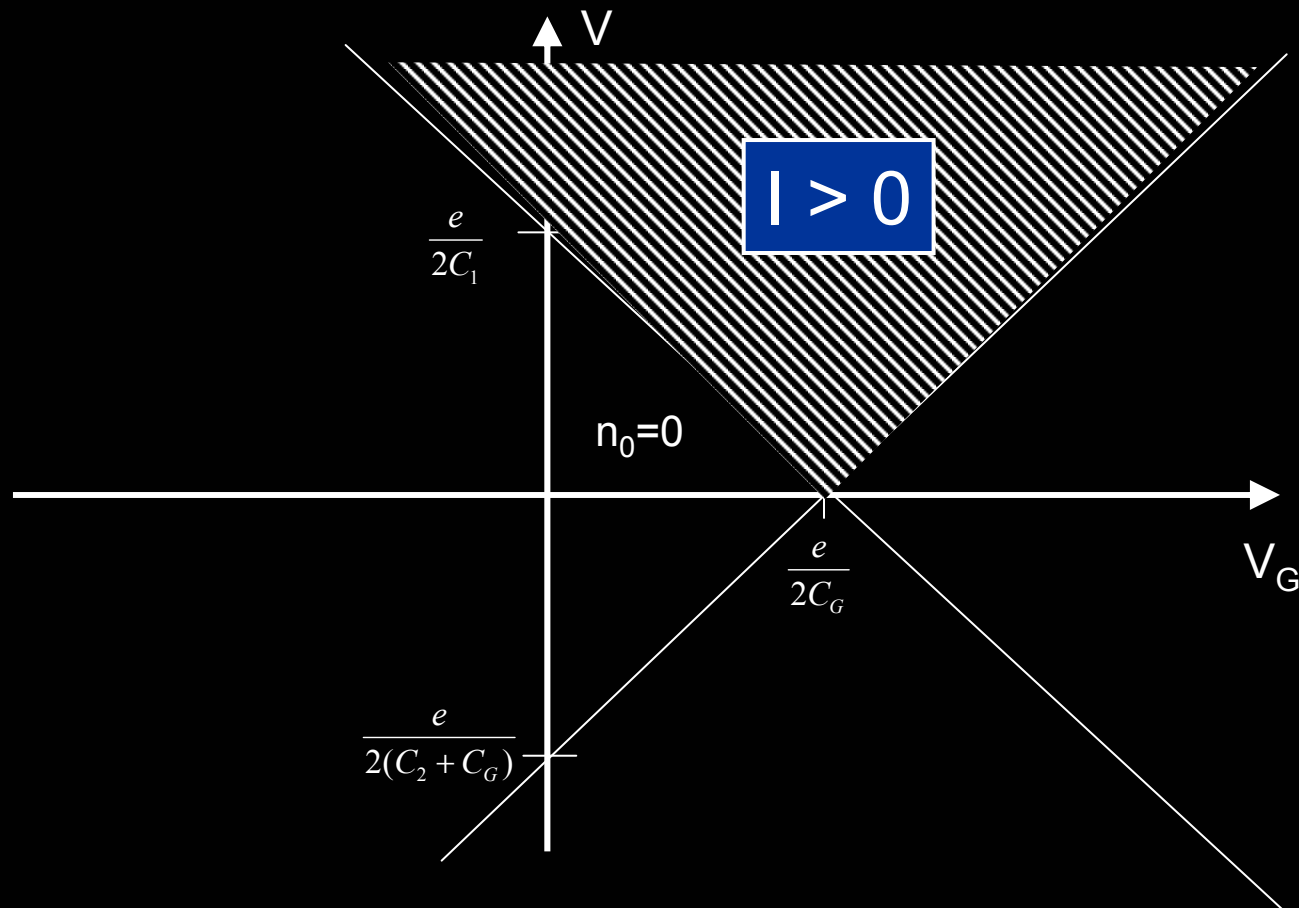

Current for 1 electrons on island:

Let $n_0=1$.

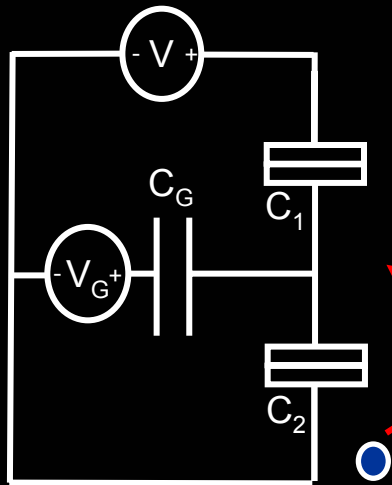

$$-\frac{3e}{2} + C_1 V + C_g V_G > 0$$

$$V > \frac{3e}{2C_1} - \frac{C_g}{C_1} V_G$$

Now $n_0=2$.

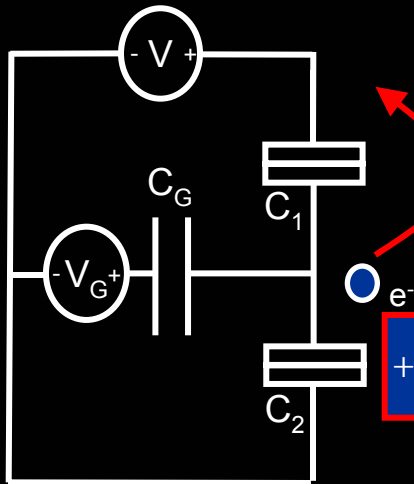

$$+\frac{3e}{2} + V(C_2 + C_G) - V_G C_g > 0$$

$$V > \frac{C_g}{(C_2 + C_G)} V_G - \frac{3e}{2(C_2 + C_G)}$$

Current?

$$V > \frac{3e}{2C_1} - \frac{C_g}{C_1} V_G$$

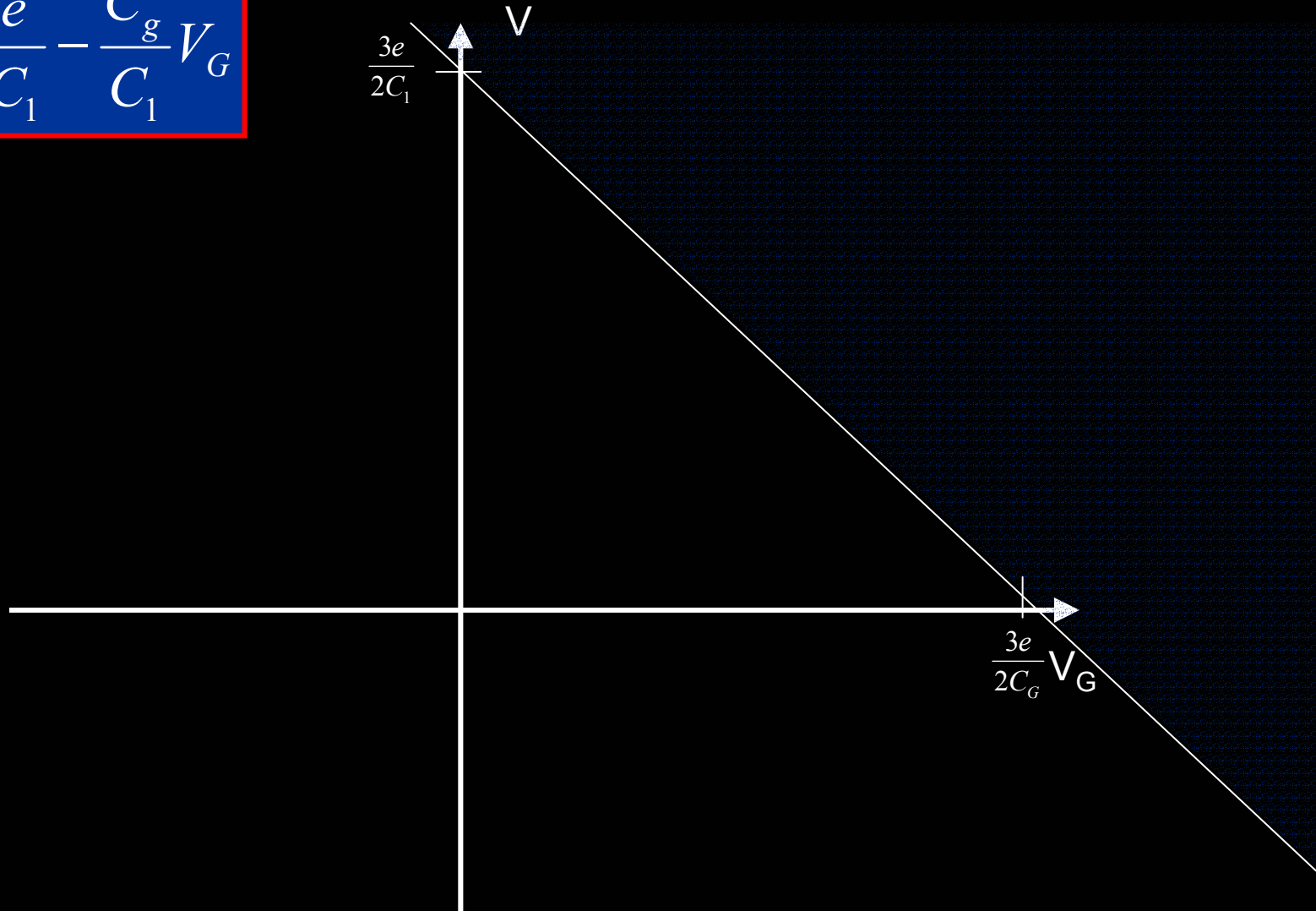

Current?

$$V > \frac{C_g}{(C_2 + C_G)} V_G - \frac{3e}{2(C_2 + C_G)}$$

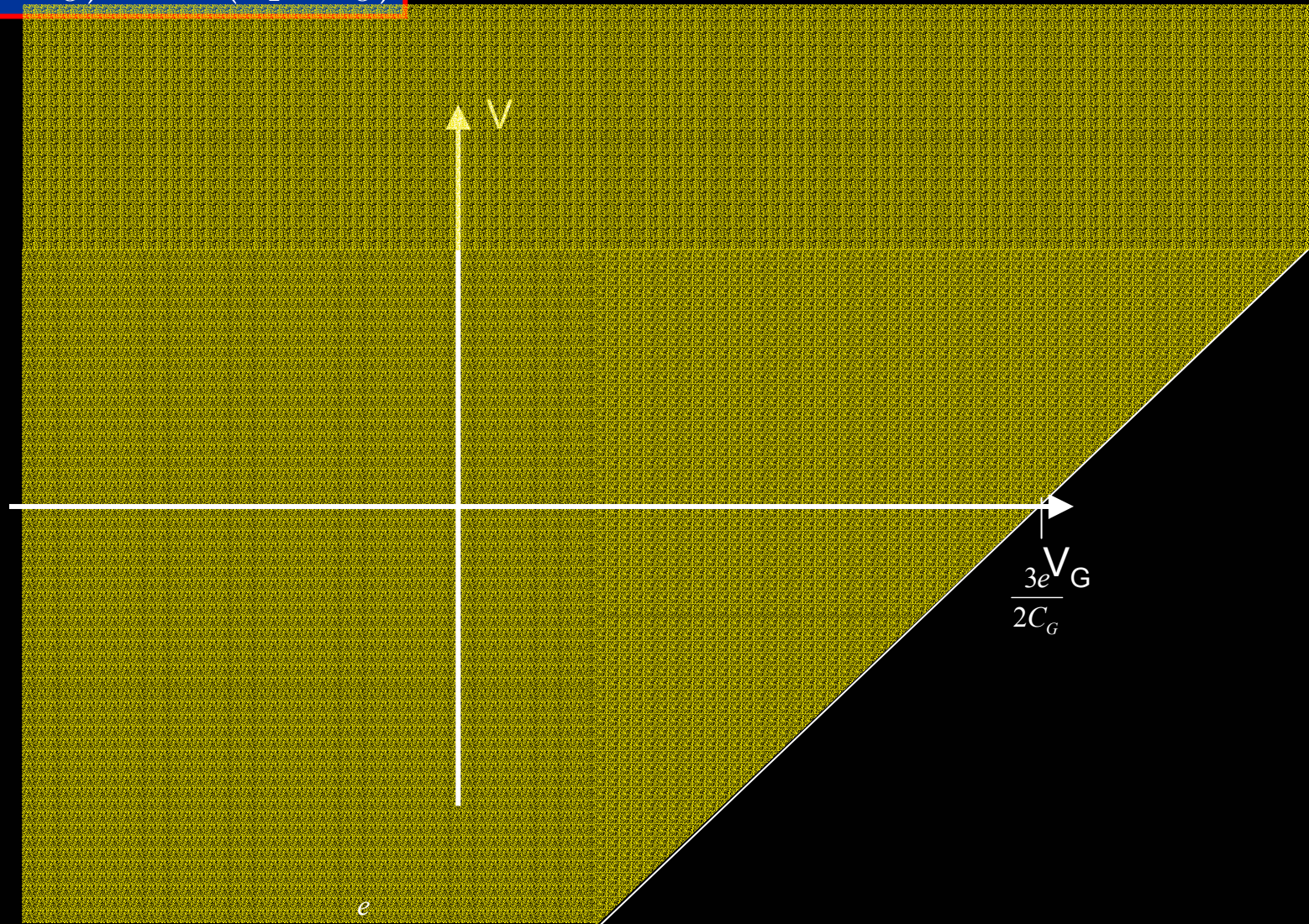

Current?

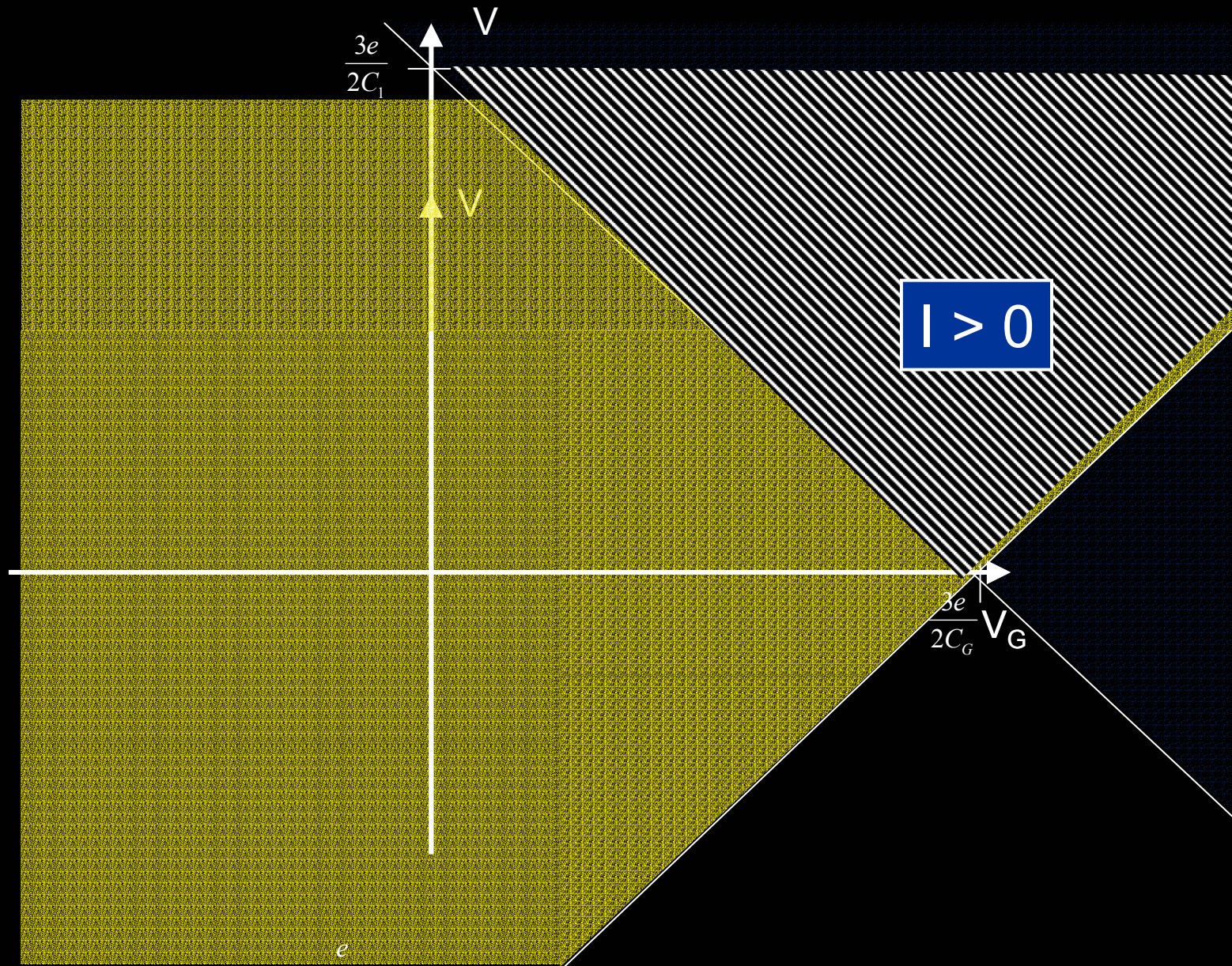

Current?

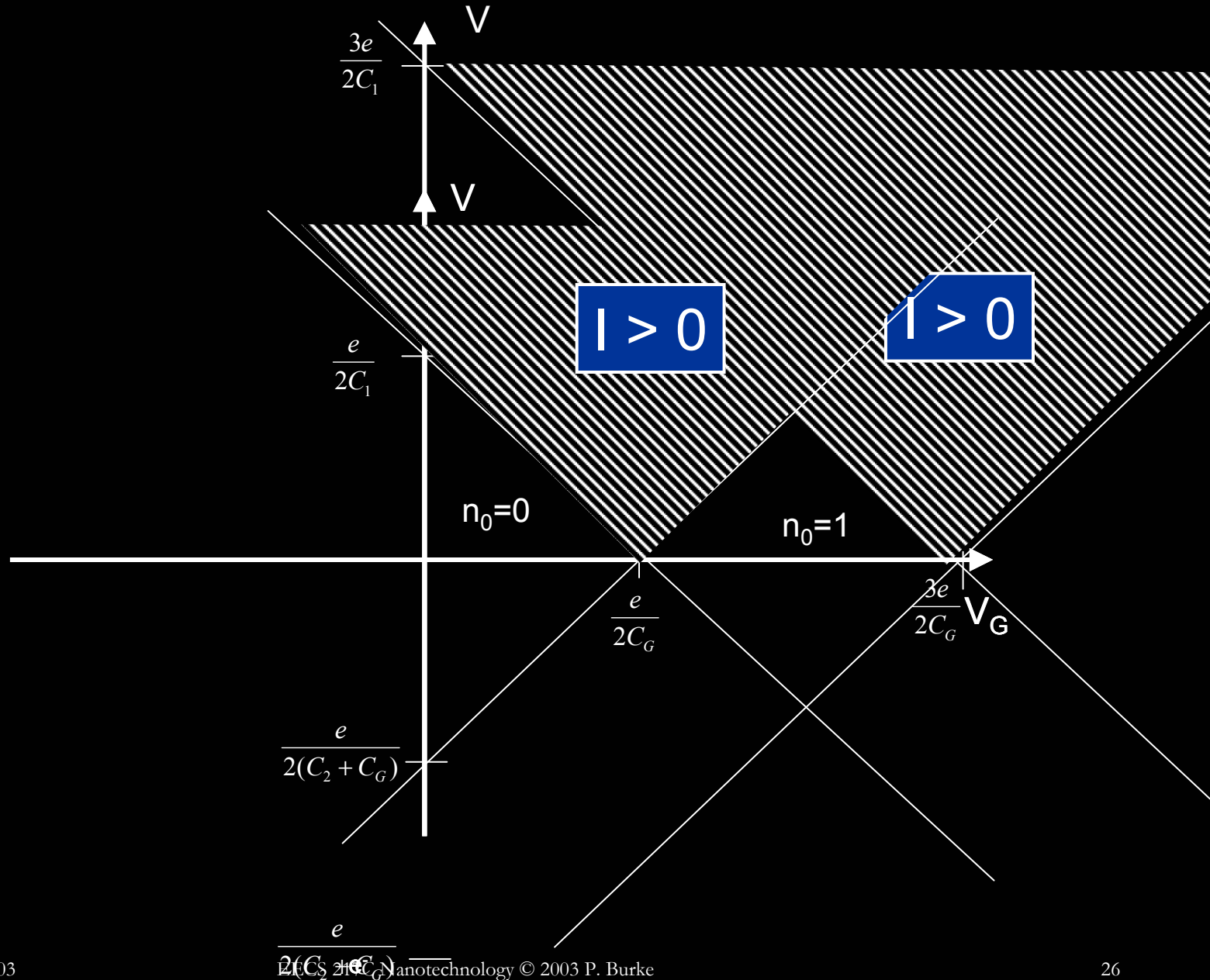

Coulomb "diamonds"

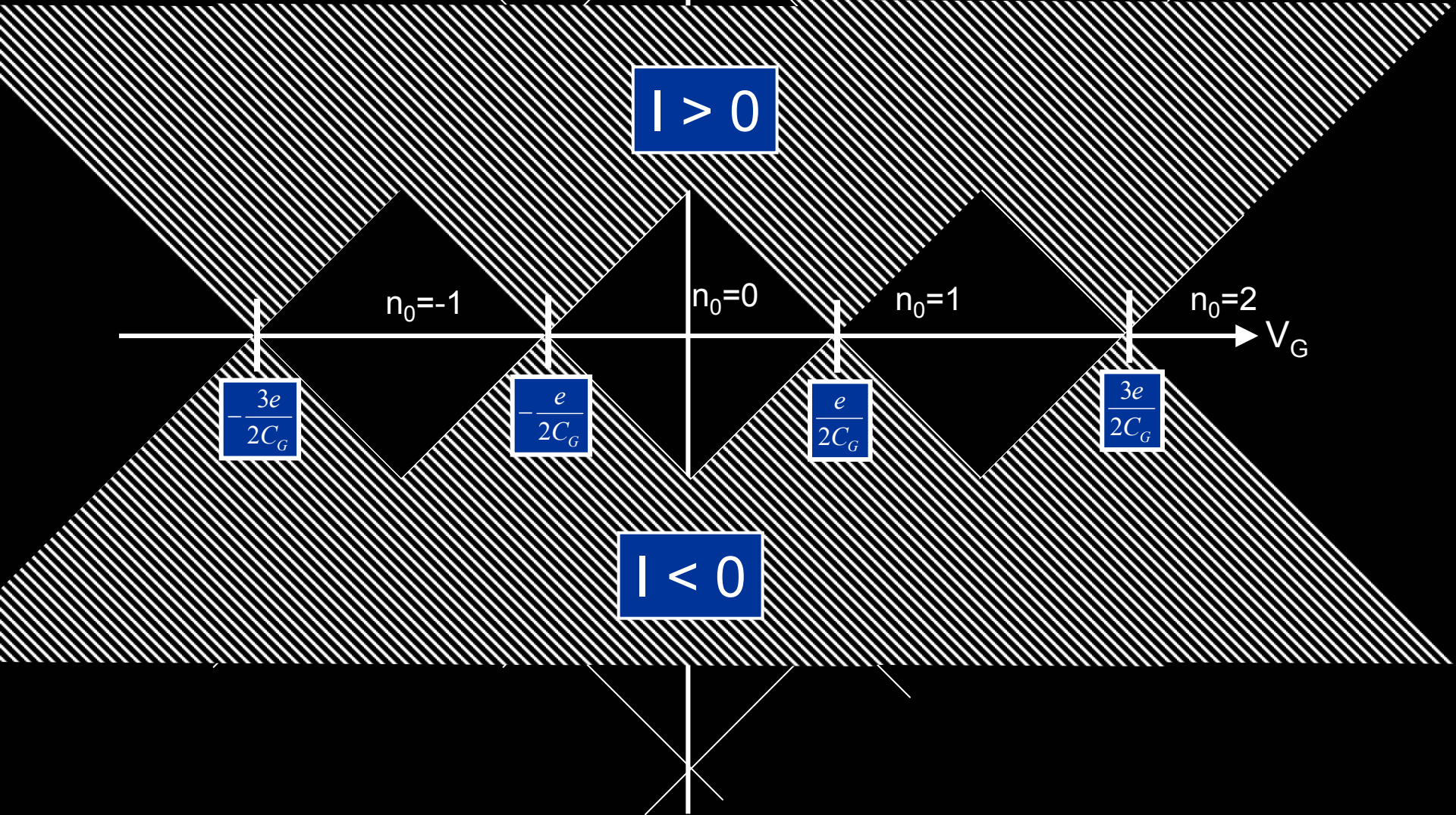

SET I-V curve vs. gate voltage

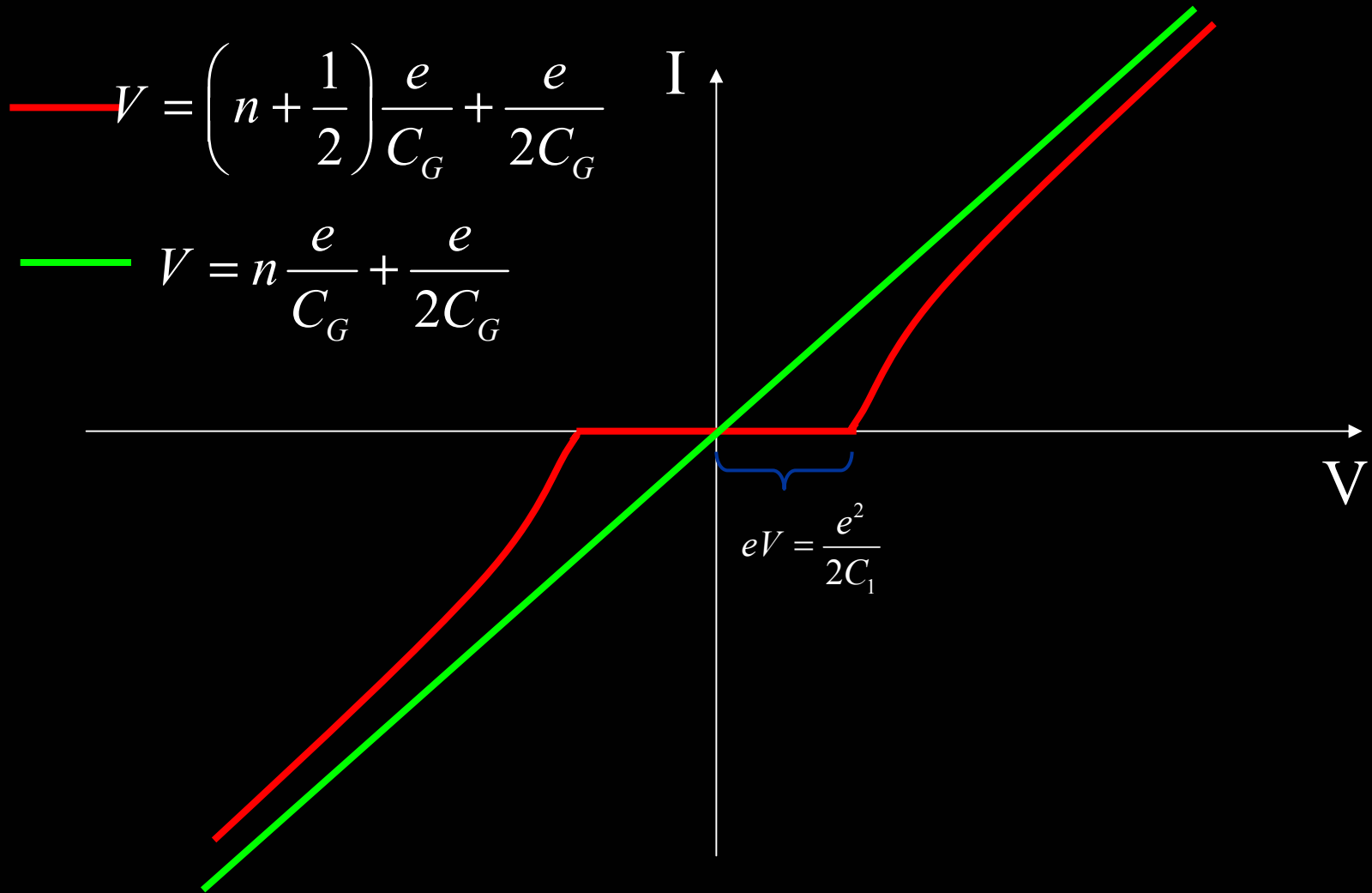

Band diagram

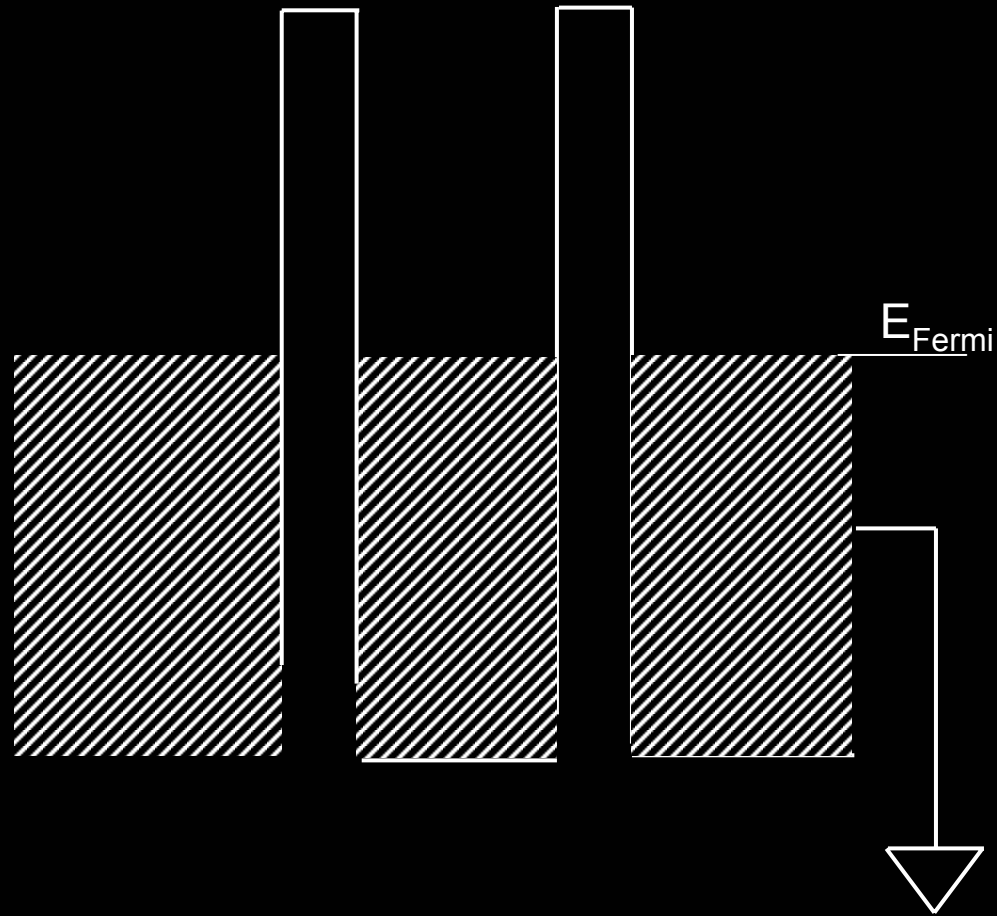
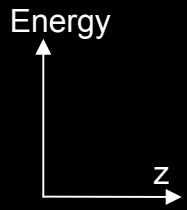

Band diagram with Coulomb "gap"

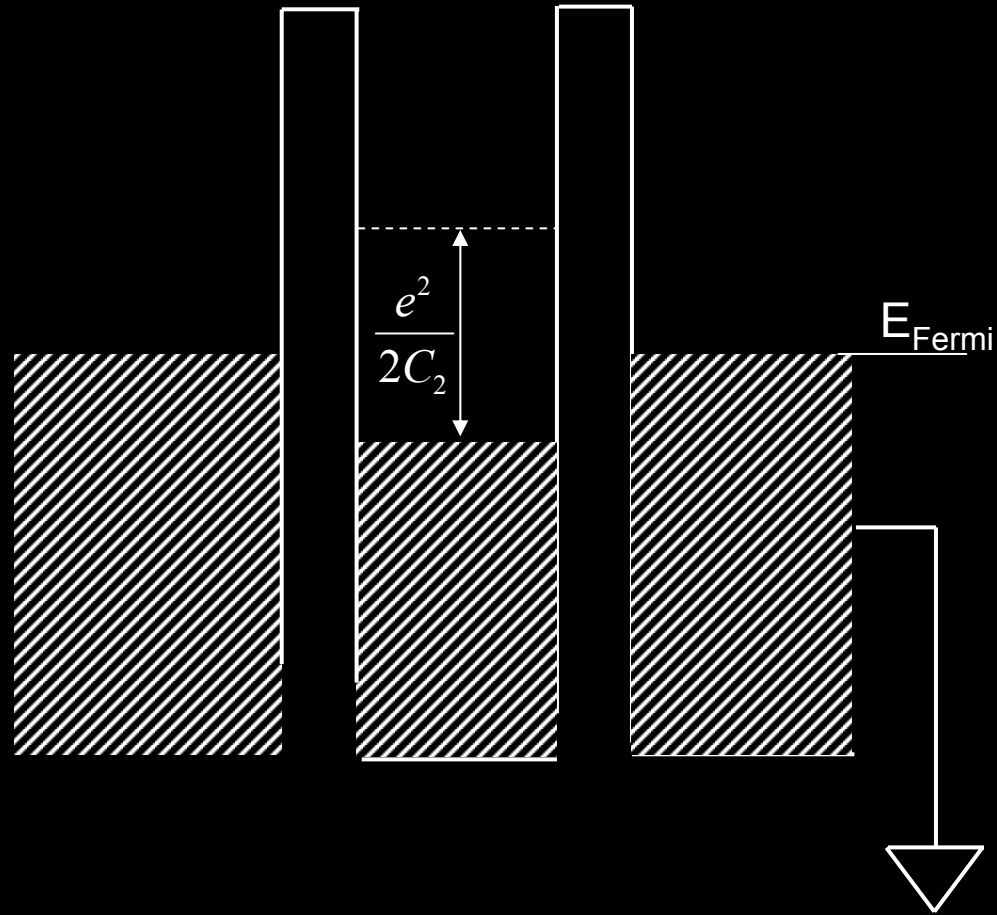
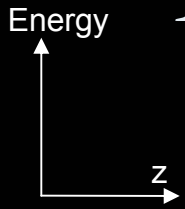

Band diagram under bias

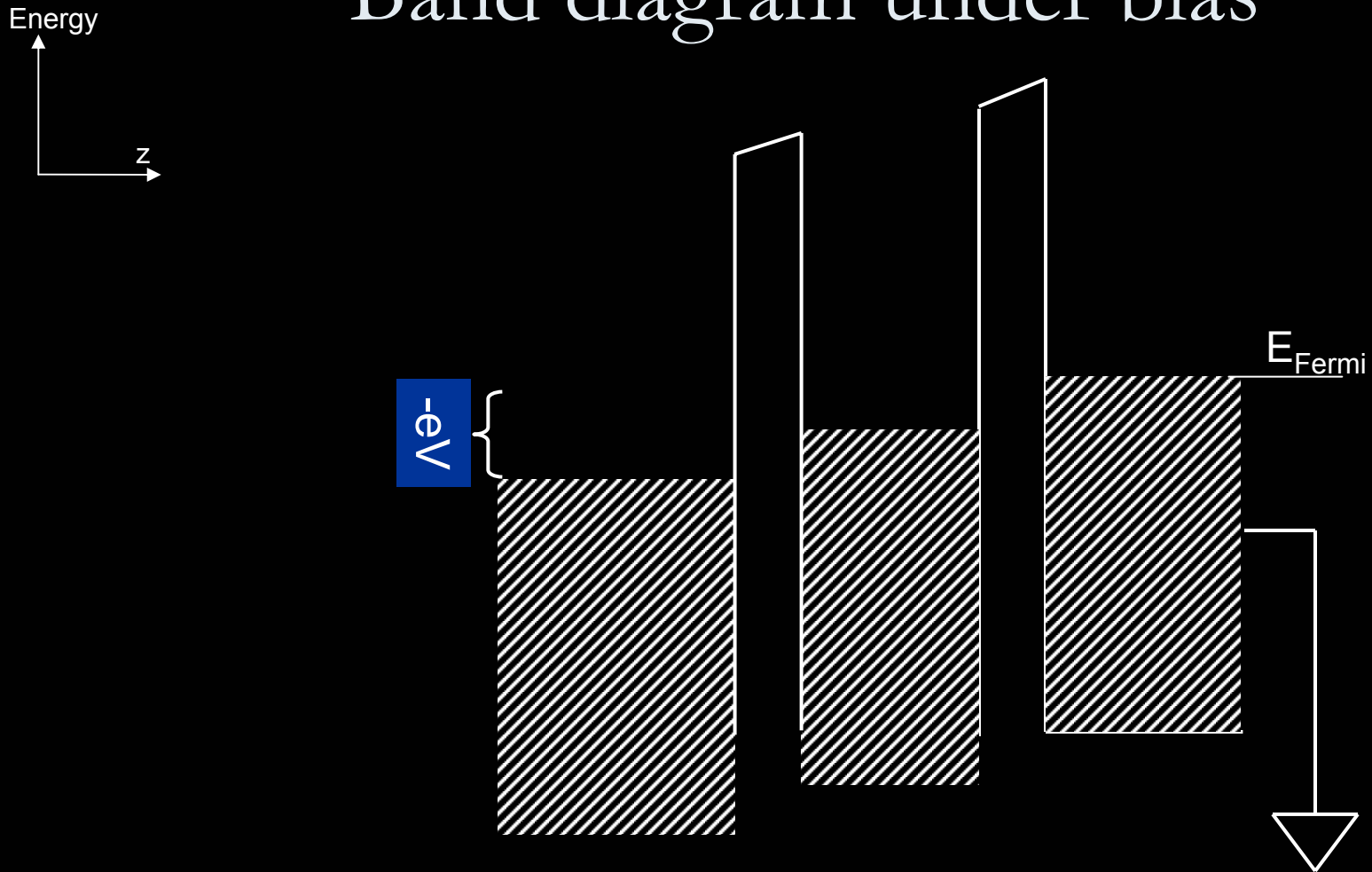

Band diagram with Coulomb "gap"

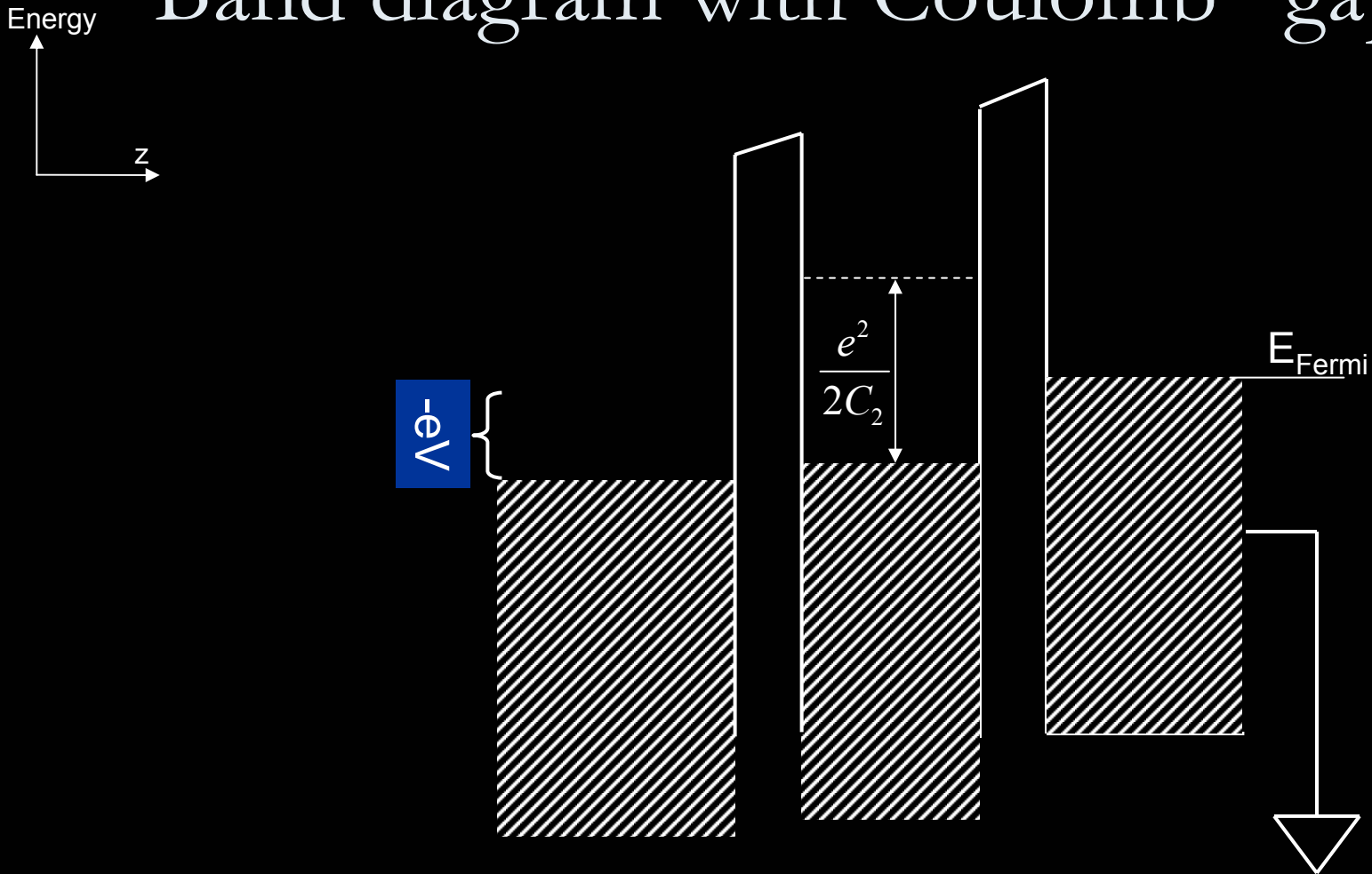

Gate voltage like a "plunger"
Moves island up/down by e^2/V_G

Band diagram with Coulomb "gap"

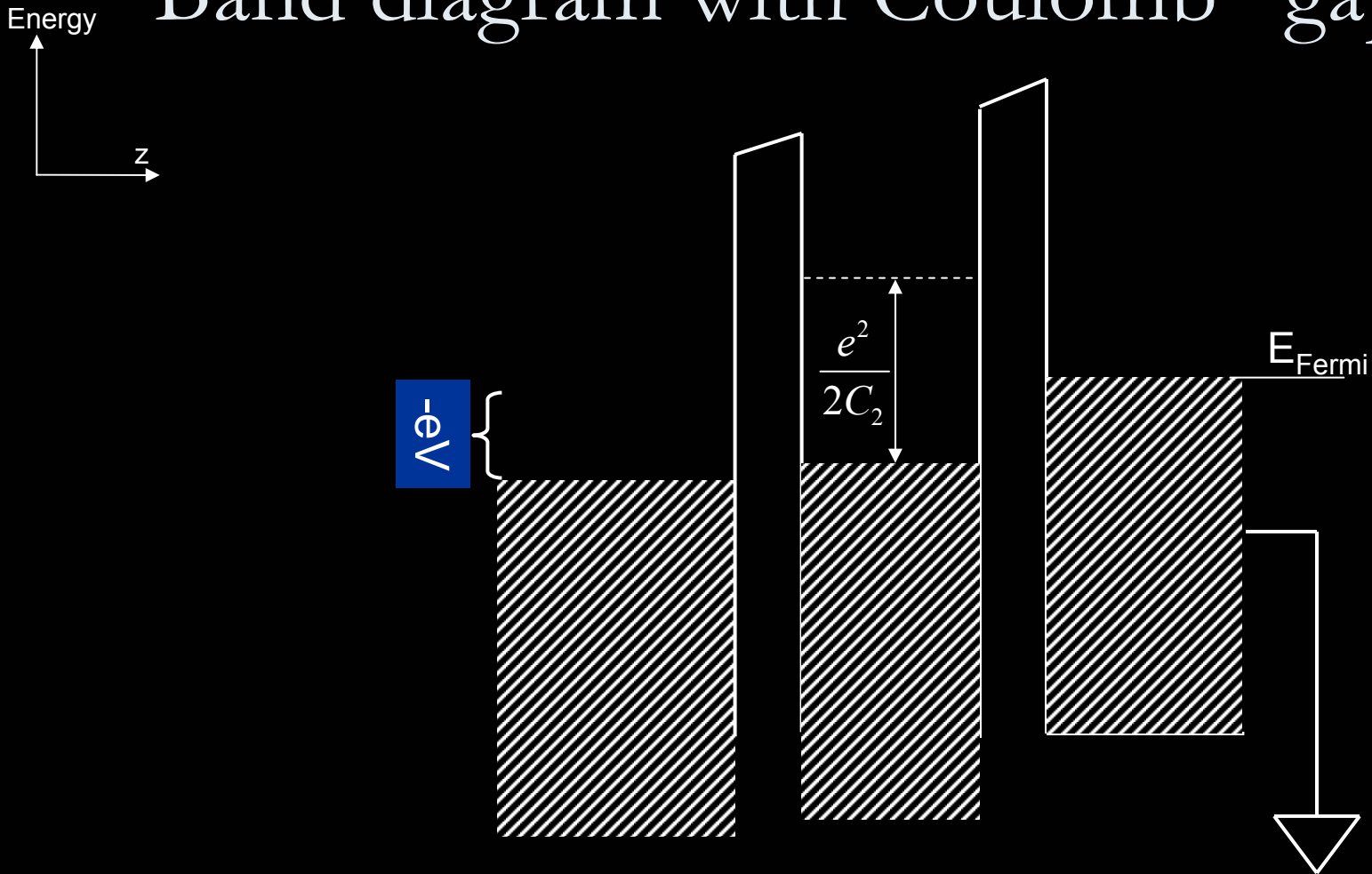

Gate voltage like a "plunger"
Moves island up/down by e^2/V_G

Zero bias conductance

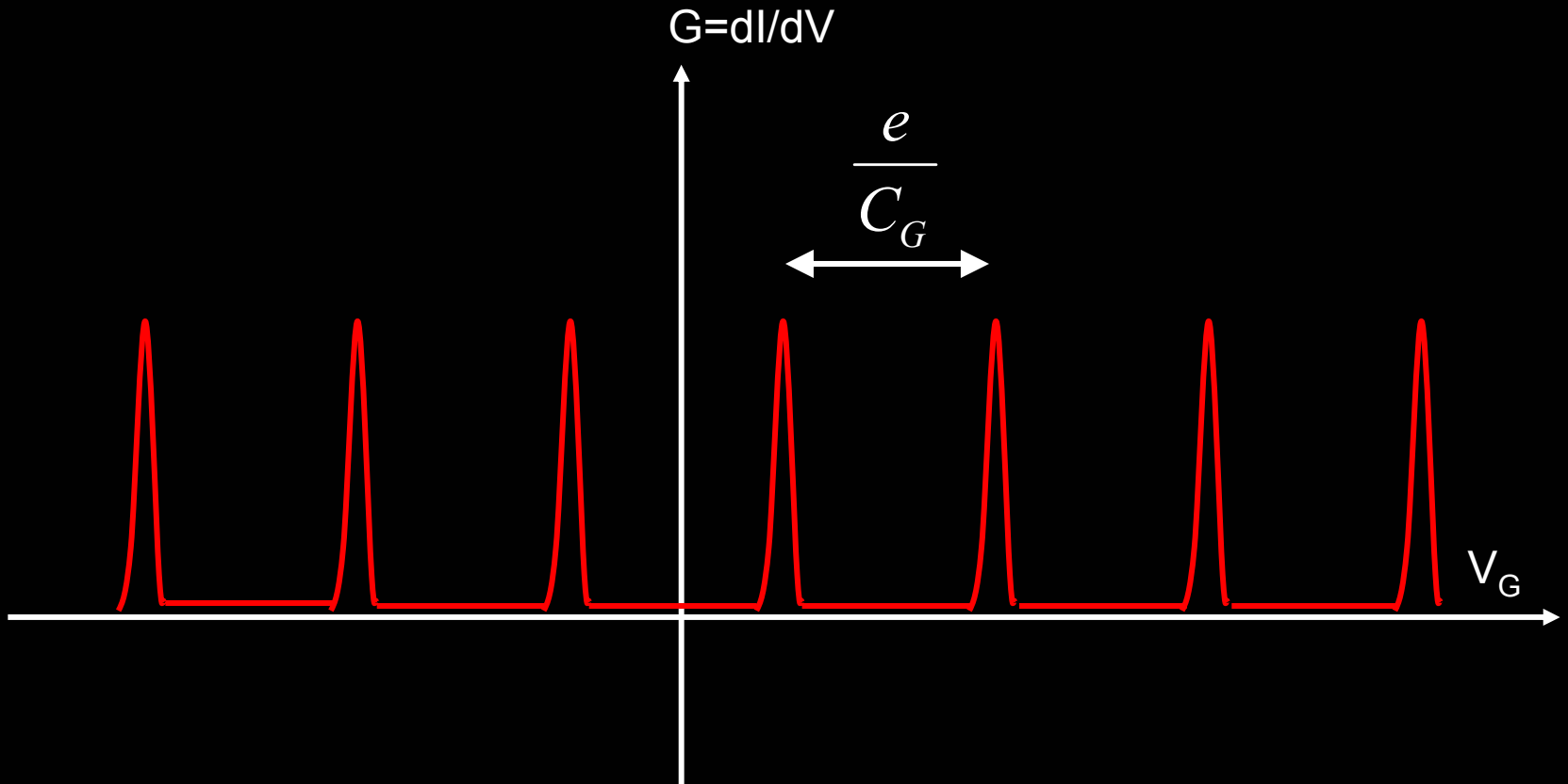

Width of peaks set by temperature.