

Lecture 7: Double tunnel junction

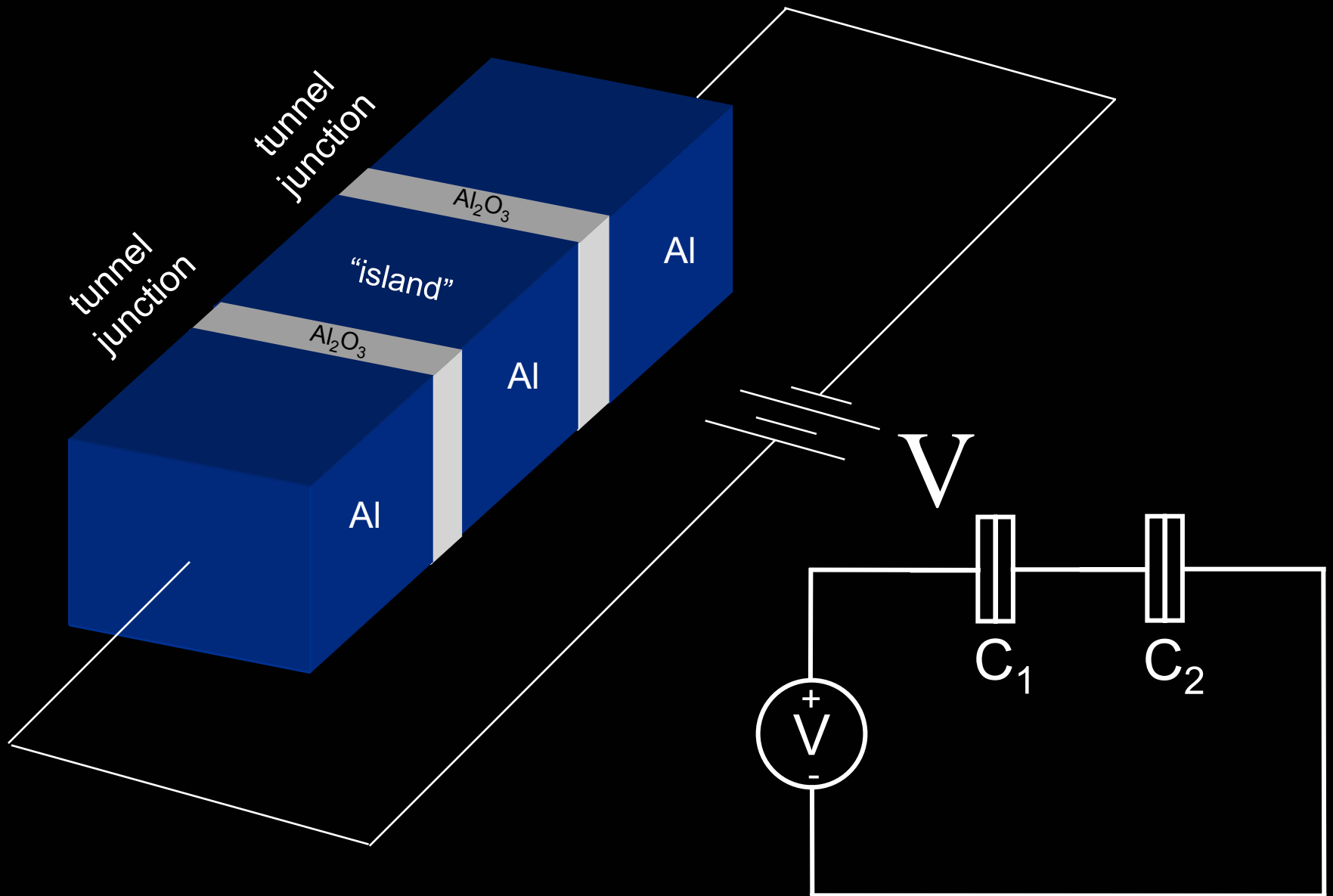

Electrostatic energy (*no tunneling*)

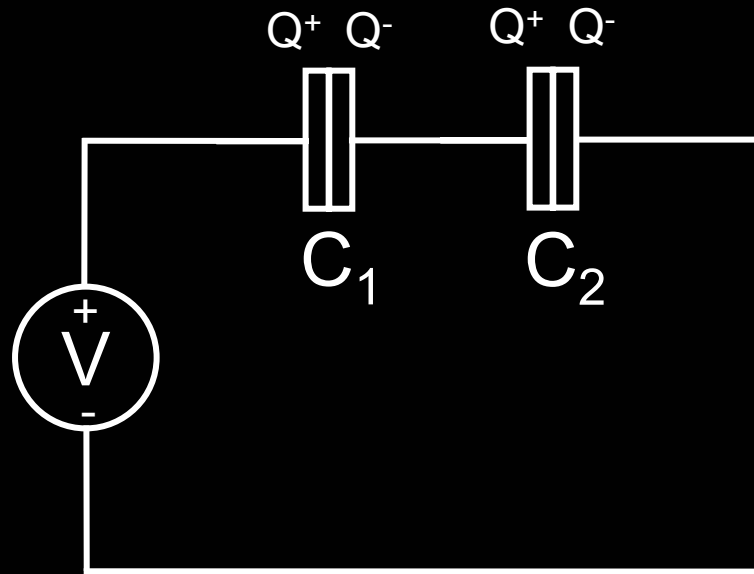

$$C_{series}^{-1} \equiv C^{-1} + C_G^{-1}$$

$$V = \frac{Q}{C_1} + \frac{Q}{C_2} = Q \left(\frac{1}{C_1} + \frac{1}{C_2} \right) = \frac{Q}{C_{series}}$$

$$E = \frac{Q^2}{2C_1} + \frac{Q^2}{2C_2} = \frac{Q^2}{2C_{series}} = \frac{1}{2} C_{series} V^2$$

Island charge

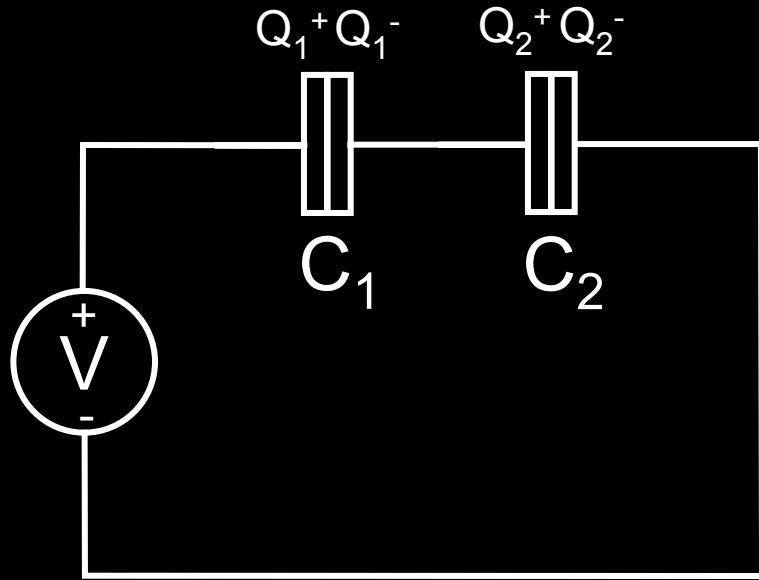

"Island charge":

$$Q_i = Q_2 - Q_1$$

Kirchoff:

$$V = \frac{Q_1}{C_1} + \frac{Q_2}{C_2}$$

Solve for Q , Q_G :

$$Q_1 = \frac{C_1(C_2V - Q_i)}{C_1 + C_2}$$

$$Q_2 = \frac{C_2(C_1V + Q_i)}{C_1 + C_2}$$

Electrostatic energy (*with tunneling*)

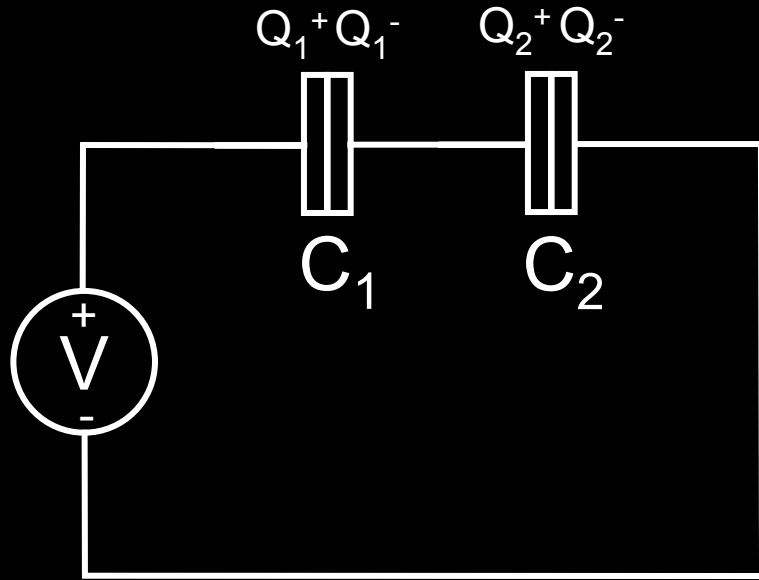

$$Q_1 = \frac{C_1(C_2V - Q_i)}{C_1 + C_2}$$

$$Q_2 = \frac{C_2(C_1V + Q_i)}{C_1 + C_2}$$

$$E = \frac{Q_1^2}{2C_1} + \frac{Q_2^2}{2C_2} = \frac{C_1C_2V^2 + Q_i^2}{2(C_1 + C_2)}$$

Free energy :

$$G = E - Q_1 V$$

From before:

$$E = \frac{C_1 C_2 V^2 + Q_i^2}{2(C_1 + C_2)}$$

$$Q_1 = \frac{C_1(C_2 V - Q_i)}{C_1 + C_2}$$

$$G = \frac{C_1 C_2 V^2 + Q_i^2}{2(C_1 + C_2)} - \frac{C_1(C_2 V - Q_i)}{C_1 + C_2} V$$

$$= \frac{1}{2} \frac{(C_1 V + Q_i)^2}{C_1 + C_2} - \frac{1}{2} C_1 V^2$$

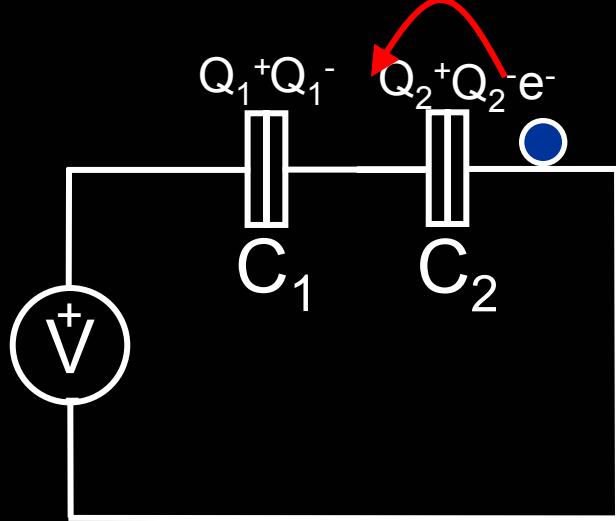

Can current flow?

$$\Delta G = \Delta E - V \Delta Q_1$$

Before:

$$Q_i = -n_0 e$$

After:

$$Q_i = -n_0 e - e$$

$$E = \frac{C_1 C_2 V^2 + Q_i^2}{2(C_1 + C_2)}$$

$$\Delta E = \frac{C_1 C_2 V^2 + (-n_0 e)^2}{2(C_1 + C_2)} - \frac{C_1 C_2 V^2 + (-n_0 e - e)^2}{2(C_1 + C_2)} =$$

$$= \frac{(-n_0 e)^2}{2(C_1 + C_2)} - \frac{(-n_0 e - e)^2}{2(C_1 + C_2)} = \frac{-2n_0 e^2 - e^2}{2(C_1 + C_2)}$$

Can current flow?

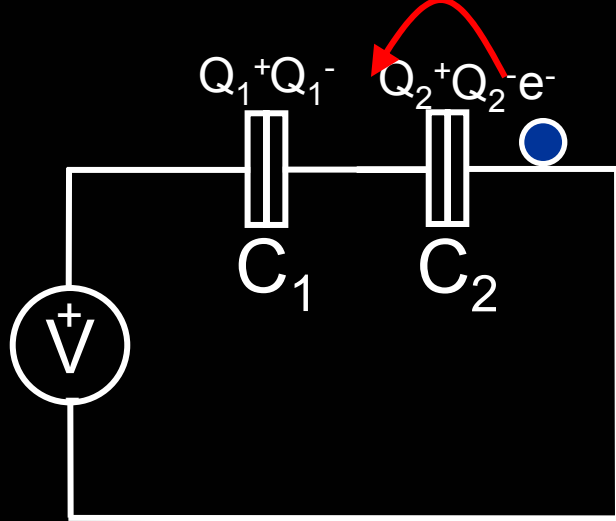

$$\Delta G = \Delta E - V \Delta Q_1$$

Before:

$$Q_i = -n_0 e$$

$$Q_1 = \frac{C_1(C_2 V - (-n_0 e))}{C_1 + C_2}$$

After:

$$Q_i = -n_0 e - e \quad Q_1 = \frac{C_1(C_2 V - (-n_0 e - e))}{C_1 + C_2}$$

$$\Delta Q_1 = -\frac{C_1 e}{C_1 + C_2}$$

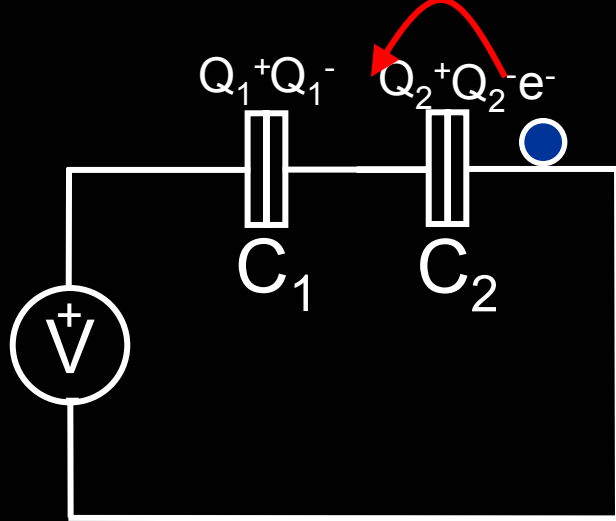

Can current flow?

$$\Delta G = \Delta E - V \Delta Q_1$$

$$\Delta E = \frac{-2n_0e^2 - e^2}{2(C_1 + C_2)}$$

$$\Delta Q_1 = -\frac{C_1e}{C_1 + C_2}$$

$$\Delta G = \frac{-2n_0e^2 - e^2}{2(C_1 + C_2)} + V \frac{C_1e}{C_1 + C_2} = \frac{e}{C_1 + C_2} \left[-n_0e - \frac{e}{2} + C_1V \right] > 0$$

$$V > \frac{e}{C_1} \left(n_0 + \frac{1}{2} \right)$$

Similarly:

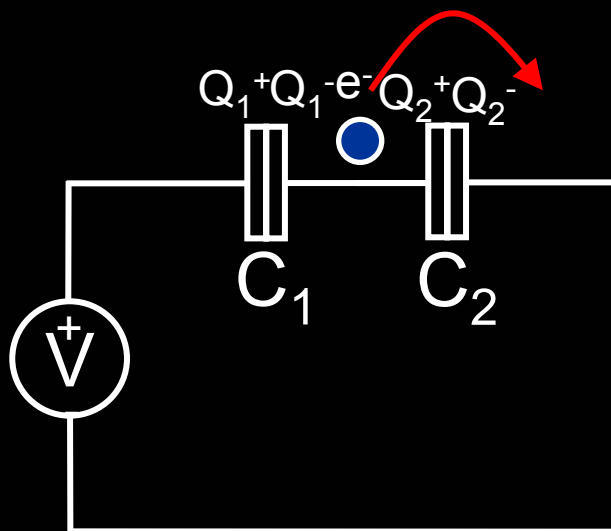

Allowed only if:

$$V < \frac{e}{C_1} \left(n_0 - \frac{1}{2} \right)$$

n_0 is the number of electrons on the island *before* the tunnel event.

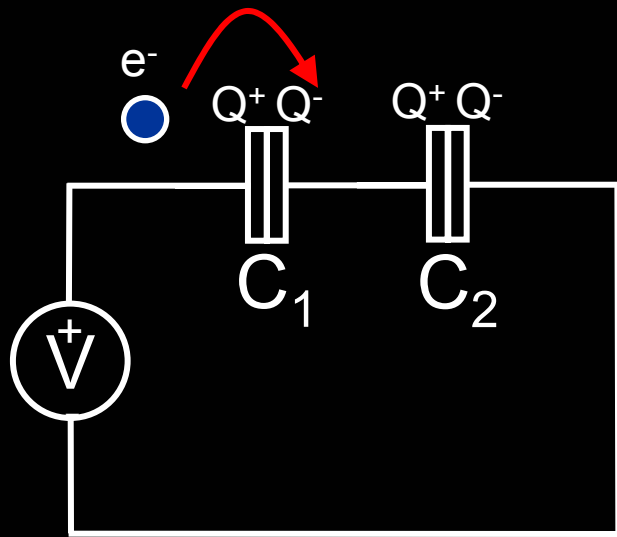

Can current flow?

$$\Delta G = \Delta E - V \Delta Q_1$$

Before:

$$Q_i = -n_0 e$$

After:

$$Q_i = -n_0 e - e$$

$$E = \frac{C_1 C_2 V^2 + Q_i^2}{2(C_1 + C_2)}$$

$$\Delta E = \frac{C_1 C_2 V^2 + (-n_0 e)^2}{2(C_1 + C_2)} - \frac{C_1 C_2 V^2 + (-n_0 e - e)^2}{2(C_1 + C_2)} =$$

$$= \frac{(-n_0 e)^2}{2(C_1 + C_2)} - \frac{(-n_0 e - e)^2}{2(C_1 + C_2)} = \frac{-2n_0 e^2 - e^2}{2(C_1 + C_2)}$$

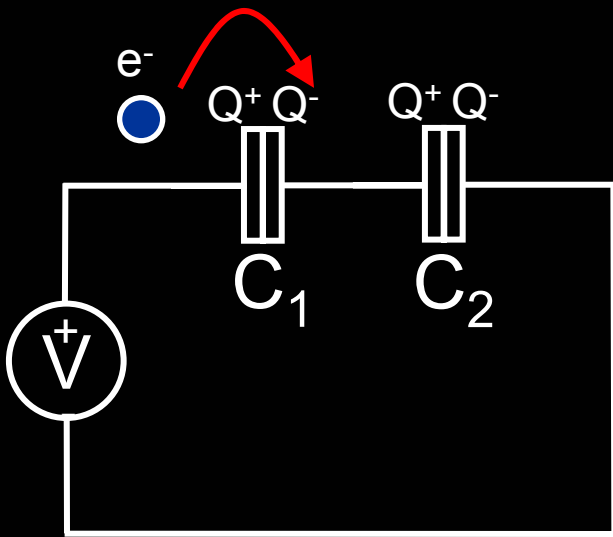

Can current flow?

$$\Delta G = \Delta E - V \Delta Q_1$$

Before:

$$Q_i = -n_0 e \quad Q_1 = \frac{C_1(C_2 V - (-n_0 e))}{C_1 + C_2}$$

After:

$$Q_i = -n_0 e - e \quad Q_1 = \frac{C_1(C_2 V - (-n_0 e - e))}{C_1 + C_2}$$

“But...”

$$\Delta Q_{1,tunnel} = e$$

$$\Delta Q_{1,polarization} = -\frac{C_1 e}{C_1 + C_2}$$

$$\Delta Q_{1,total} = e - \frac{C_1 e}{C_1 + C_2} = \frac{C_1 + C_2}{C_1 + C_2} e - \frac{C_1 e}{C_1 + C_2} = \frac{C_2 e}{C_1 + C_2}$$

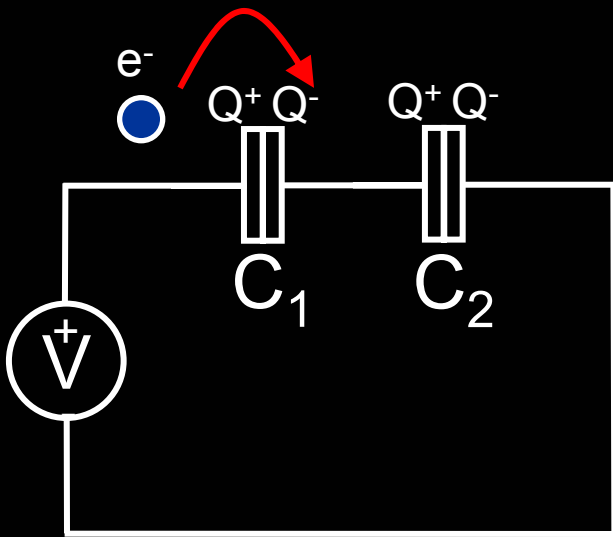

Can current flow?

$$\Delta G = \Delta E - V \Delta Q_1$$

$$\Delta Q_{1,total} = \frac{C_2 e}{C_1 + C_2}$$

$$\Delta E = \frac{-2n_0 e^2 - e^2}{2(C_1 + C_2)}$$

$$\Delta G = \frac{-2n_0 e^2 - e^2}{2(C_1 + C_2)} + V \frac{C_2 e}{C_1 + C_2} = \frac{e}{C_1 + C_2} \left[-n_0 e - \frac{e}{2} - C_2 V \right] > 0$$

$$V < -\frac{e}{C_2} \left(n_0 + \frac{1}{2} \right)$$

Similarly:

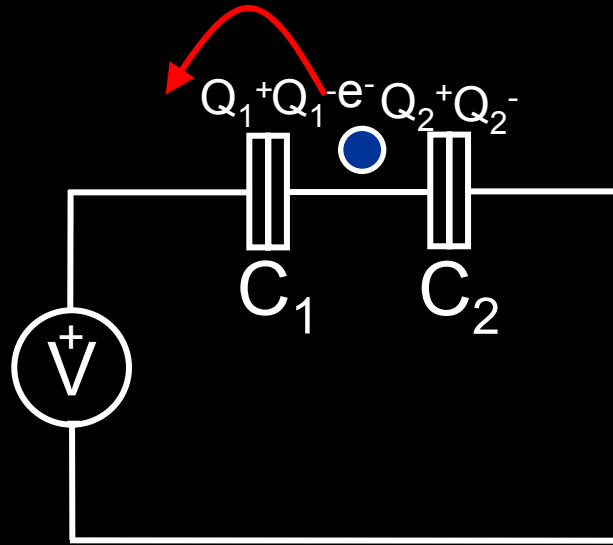

Allowed only if:

$$V > -\frac{e}{C_2} \left(n_0 - \frac{1}{2} \right)$$

n_0 is the number of electrons on the island *before* the tunnel event.

Summary

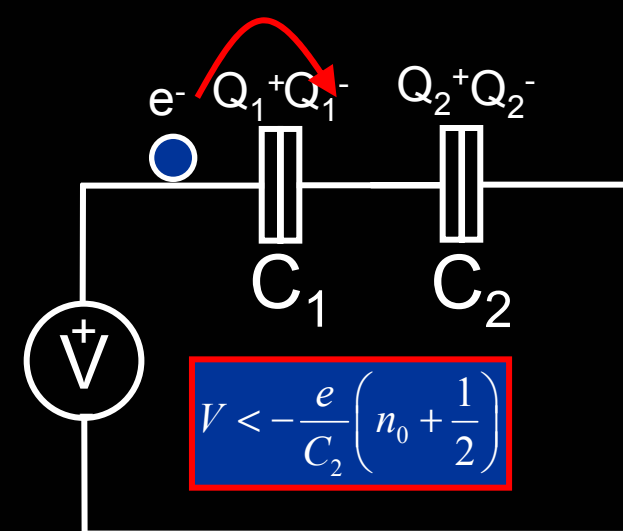
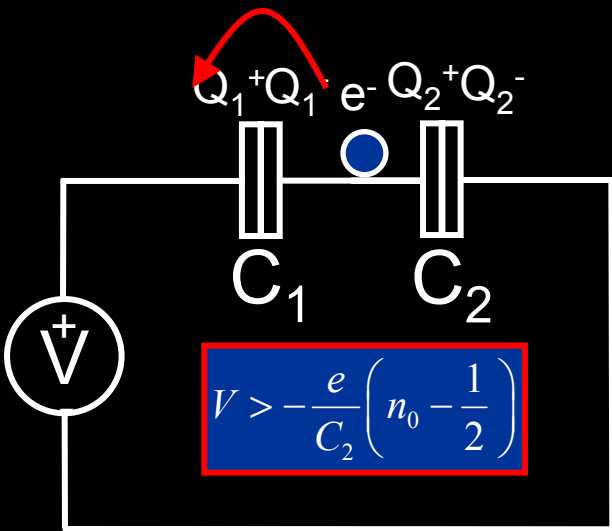
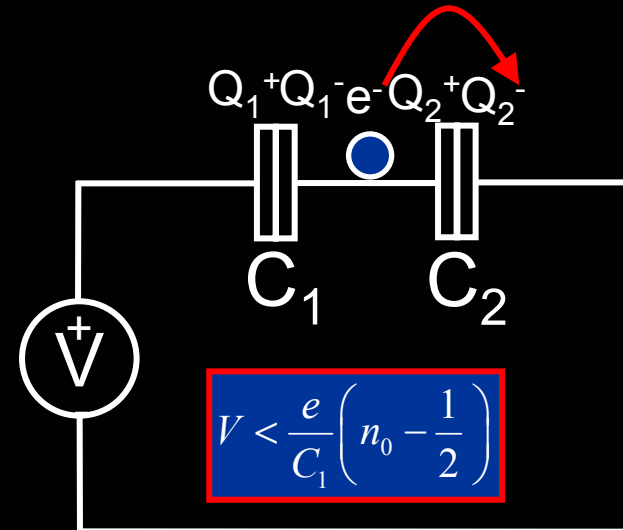
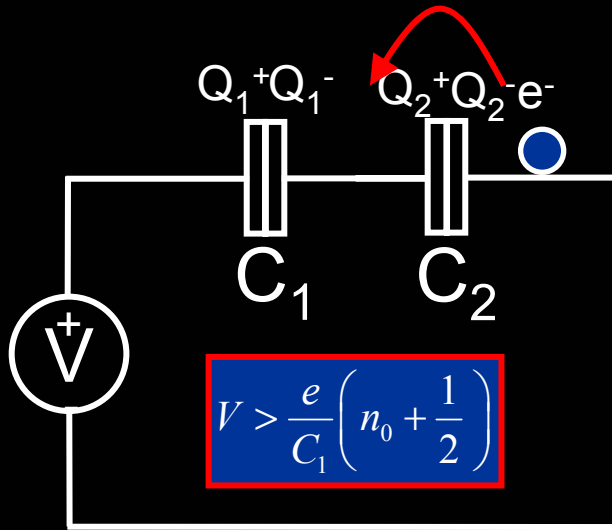

Current

Let $n_0=0$. Let $C_1 = C_2$

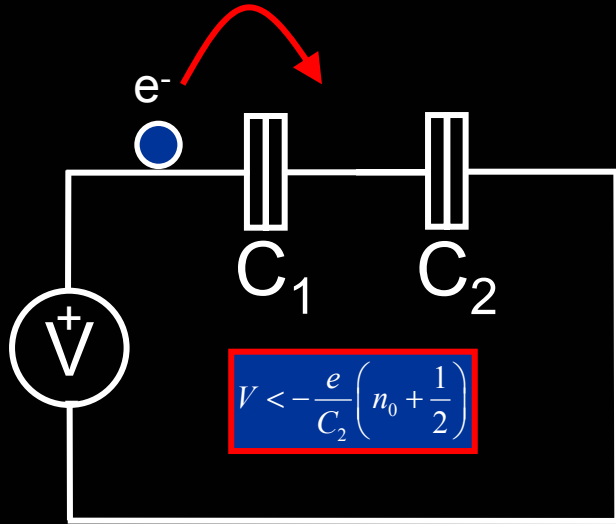

$$V < -\frac{e}{2C_2}$$

Now $n_0=1$.

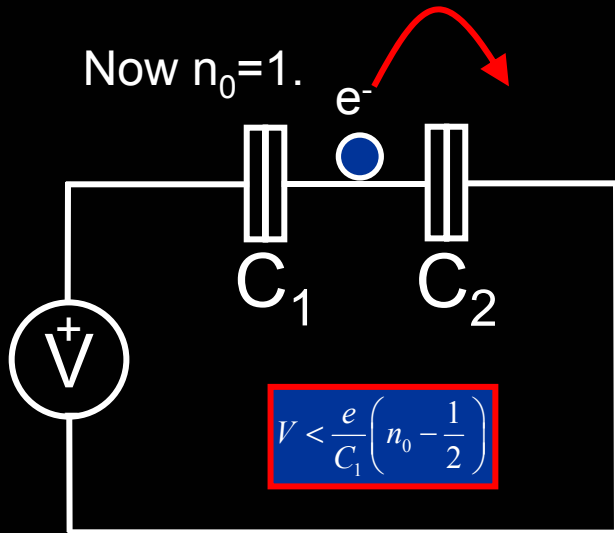

$$V < \frac{e}{2C_2}$$

Current

Let $n_0=0$.

Let $C_1 = C_2$

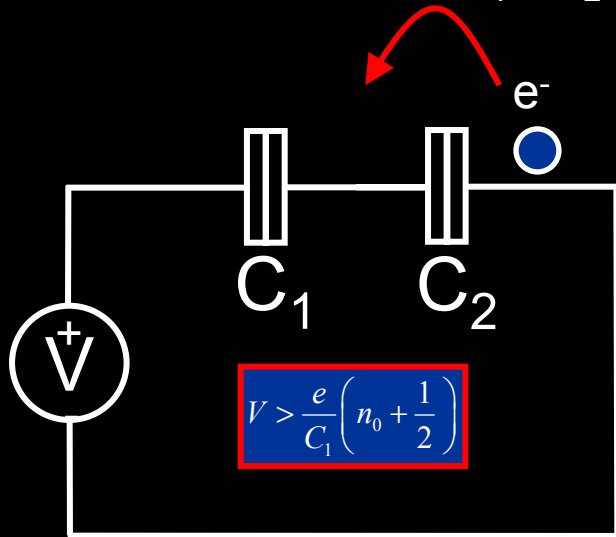

$$V > \frac{e}{2C_2}$$

Now $n_0=1$.

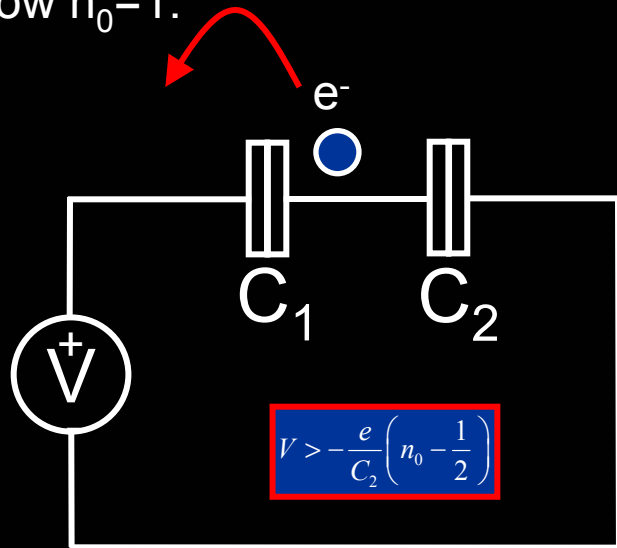

$$V > -\frac{e}{2C_2}$$

Coulomb blockade

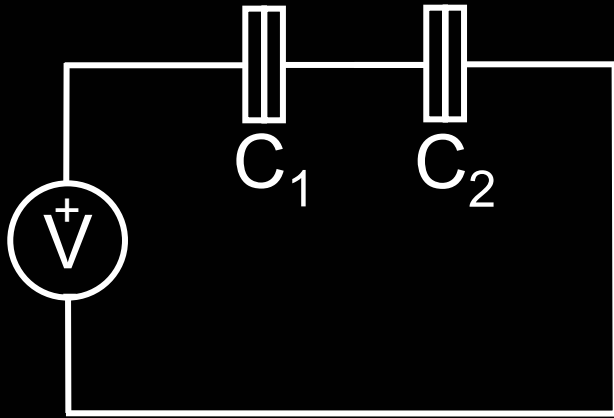

Let $C_1 = C_2$
No current:

$$-\frac{e}{2C_2} < V < \frac{e}{2C_2}$$

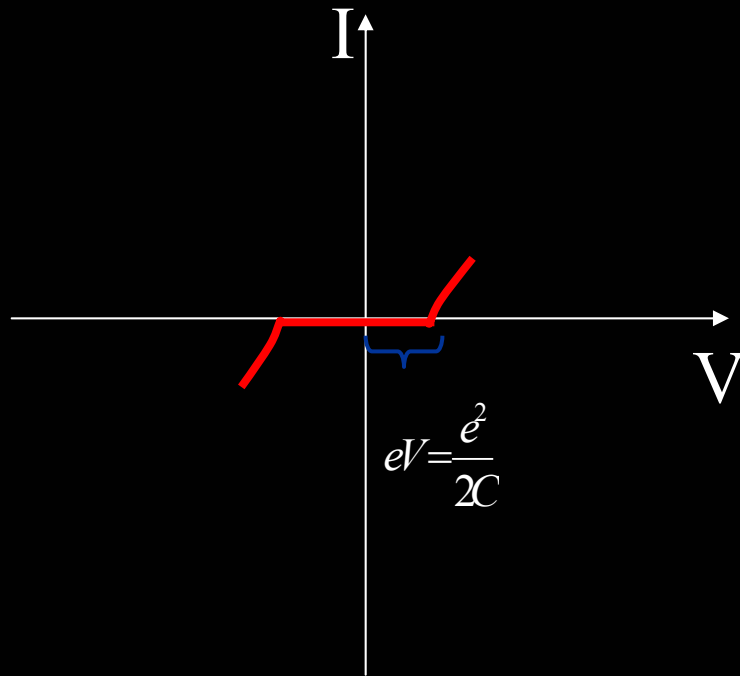

From quantum circuit theory,
works even when voltage biased.

In single junction, Coulomb
blockade *hard* to observe.

In double junction, Coulomb
blockade *easy* to observe.

Band diagram

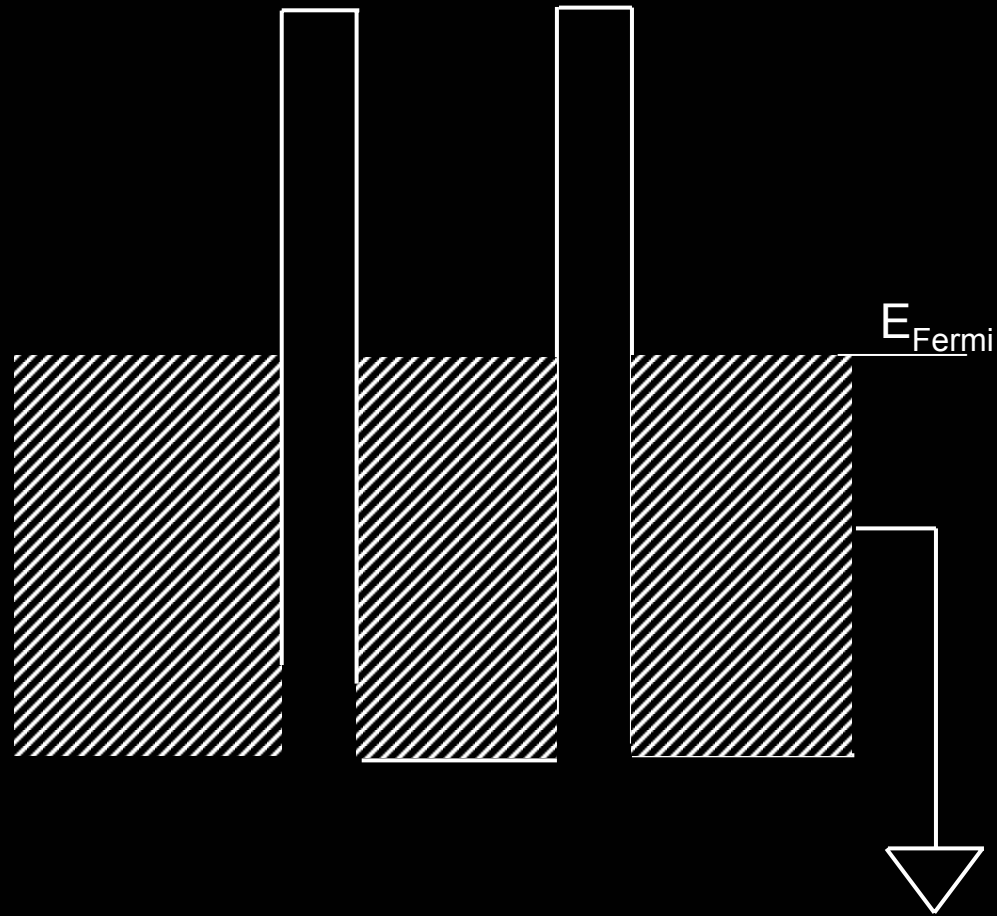
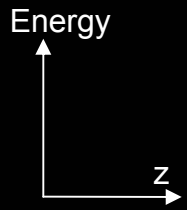

Band diagram with Coulomb "gap"

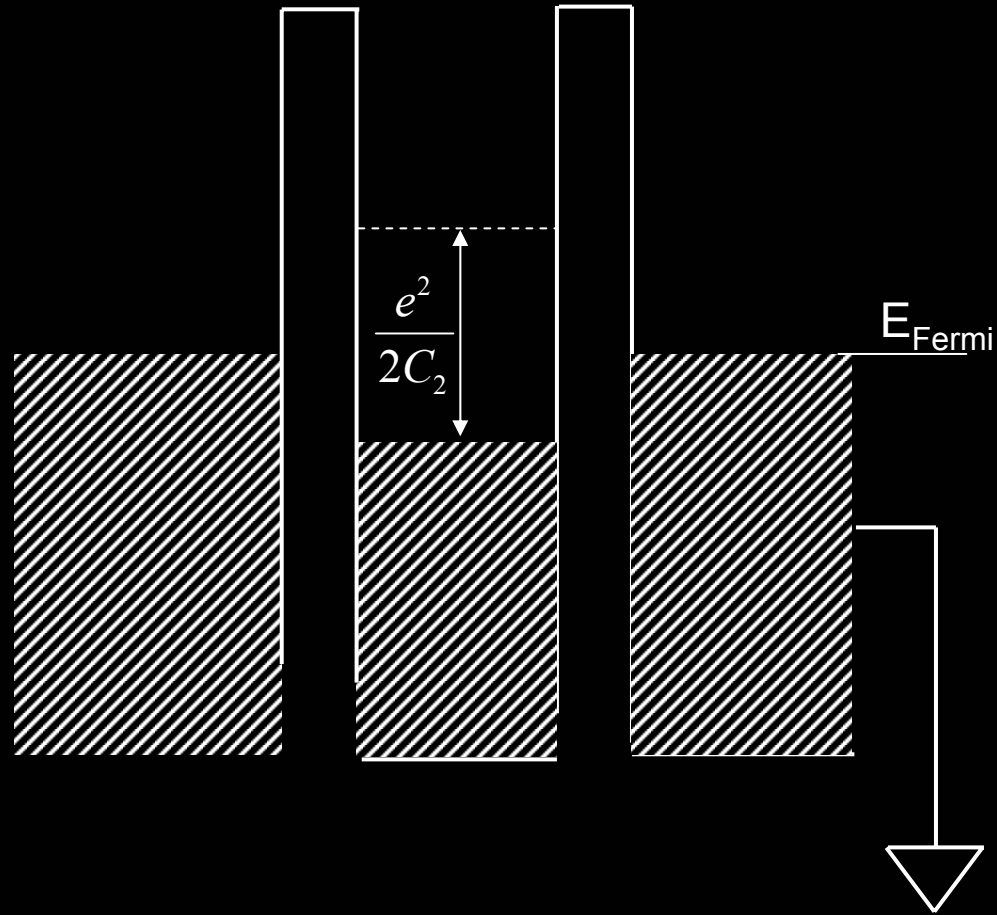
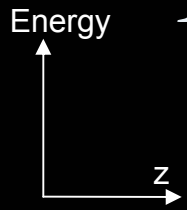

Band diagram under bias

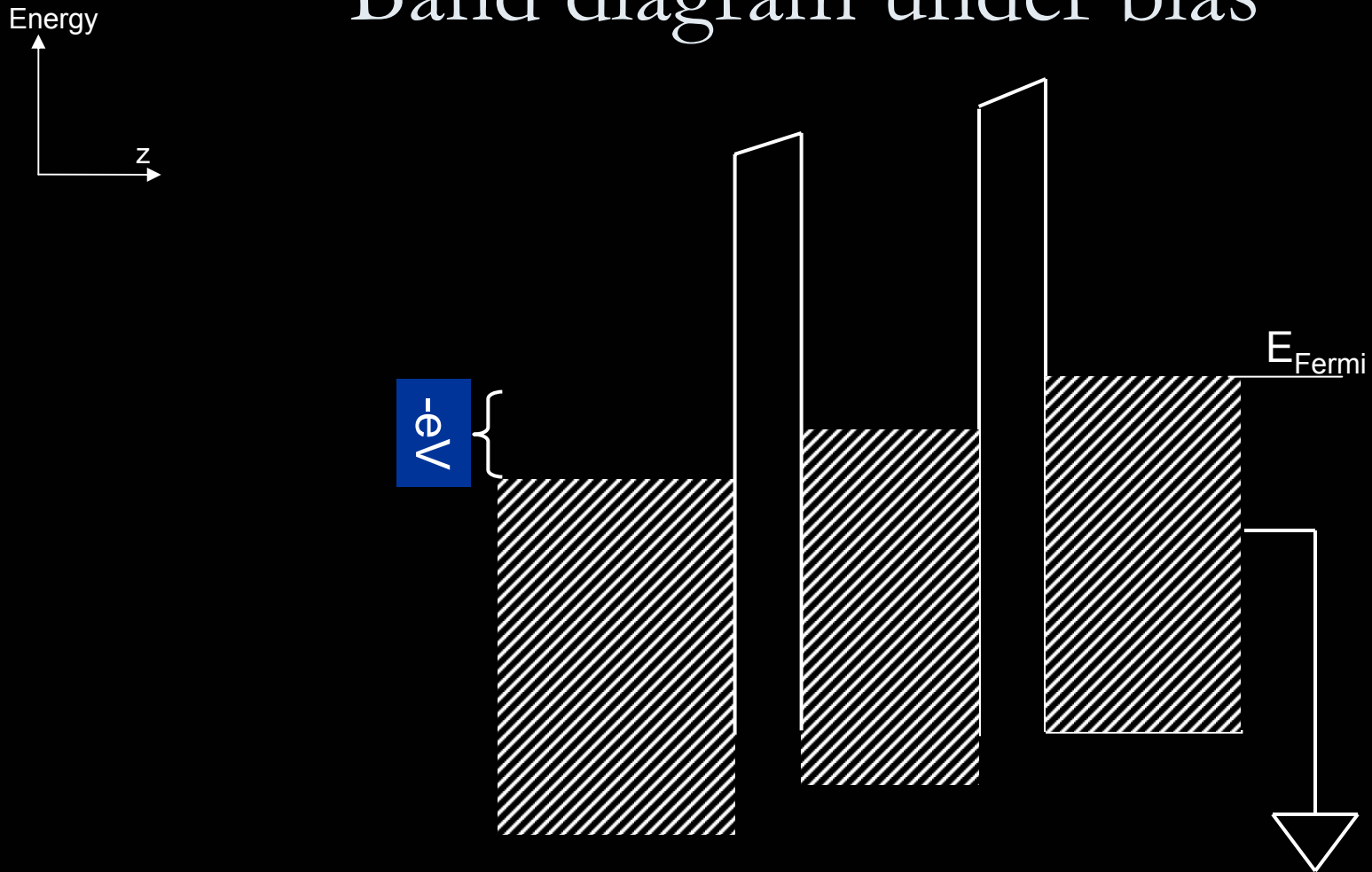

Band diagram with Coulomb "gap"

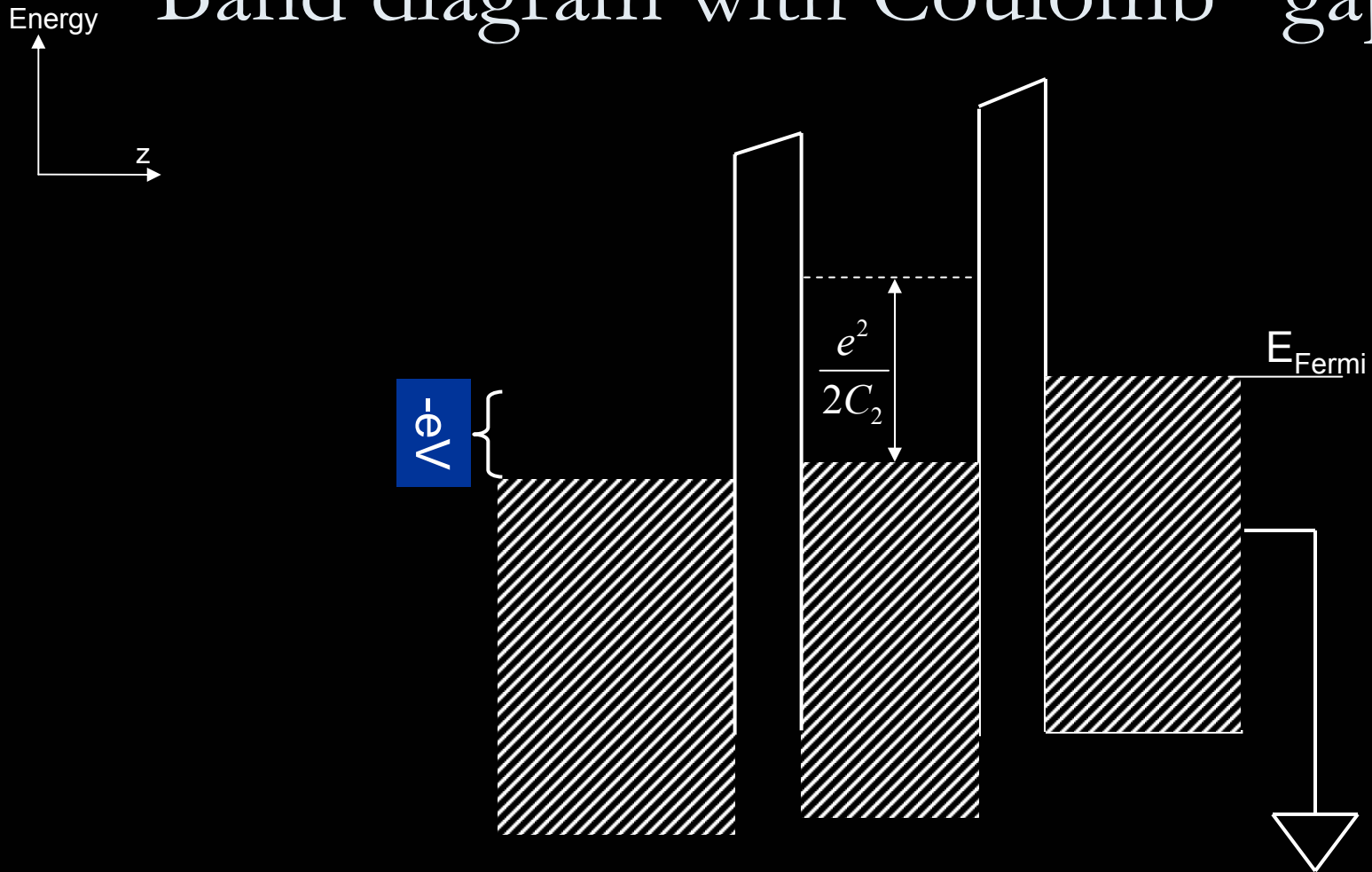

Band diagram with Coulomb "gap"

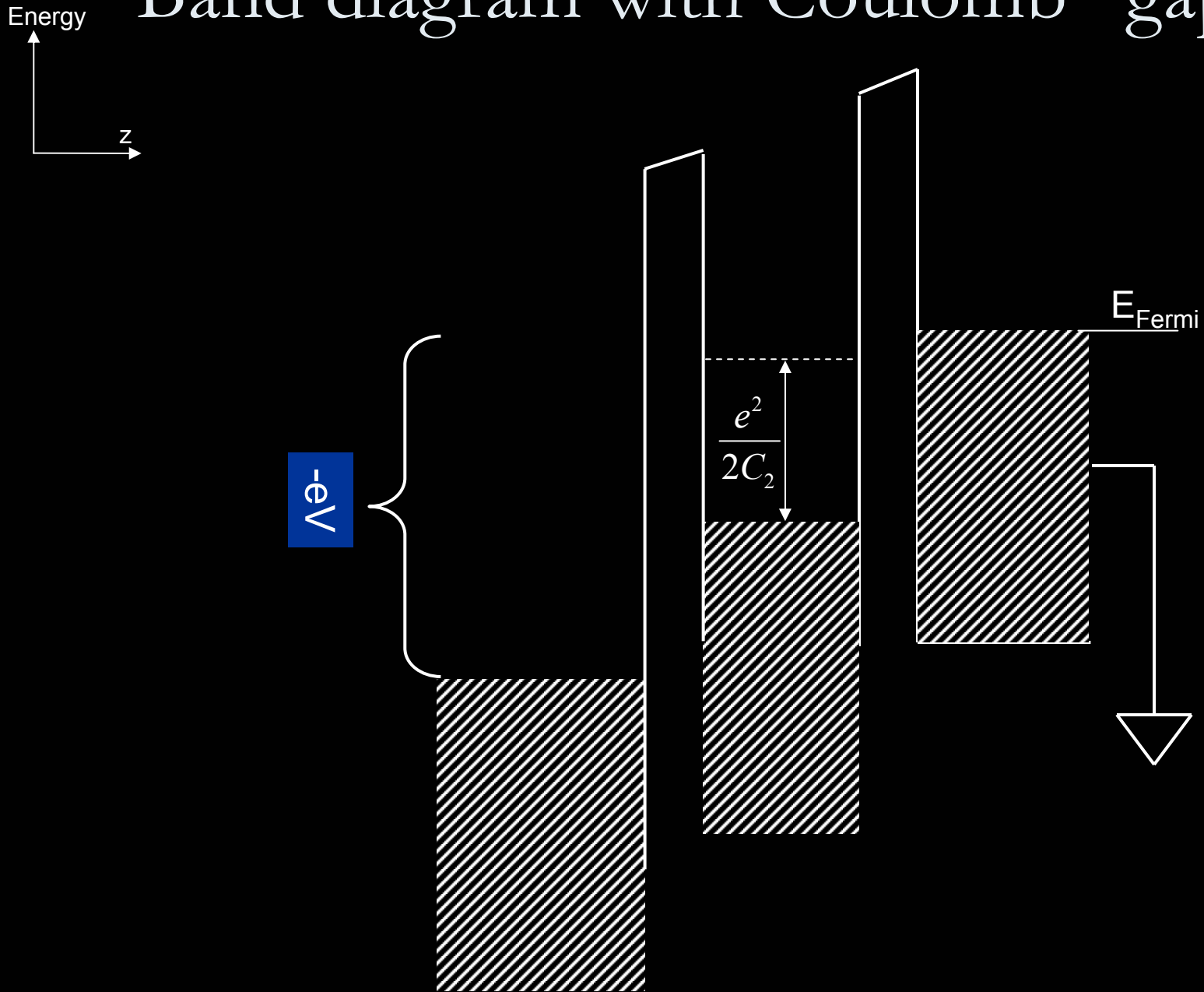

Higher voltages

Let $n_0=1$. Let $C_1=C_2$

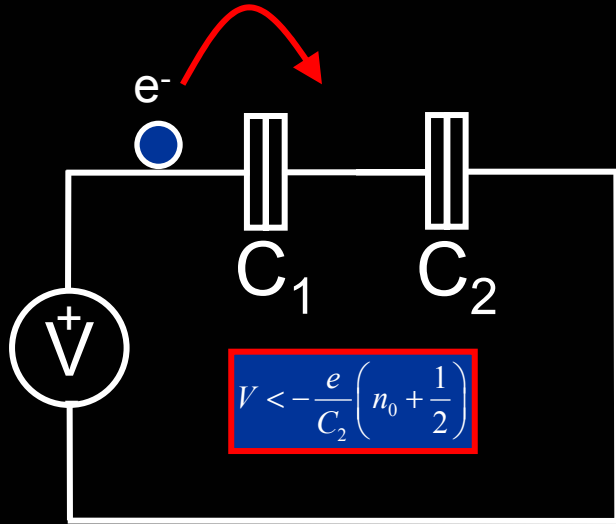

$$V < -\frac{e}{C_2} \left(n_0 + \frac{1}{2} \right)$$

$$V < -\frac{3e}{2C_2}$$

Now $n_0=2$.

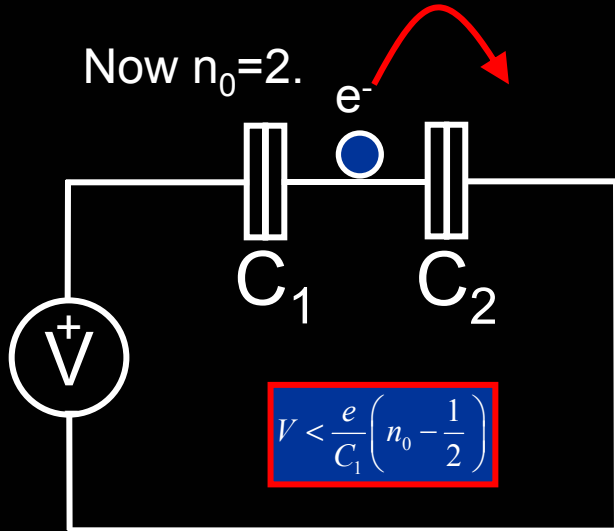

$$V < \frac{e}{C_1} \left(n_0 - \frac{1}{2} \right)$$

$$V < -\frac{3e}{2C_2}$$

Higher voltages

Let $n_0=1$.

Let $C_1 = C_2$

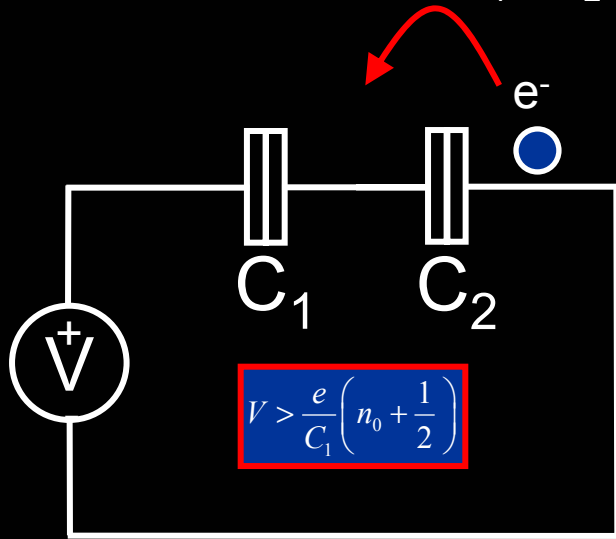

$$V > \frac{3e}{2C_2}$$

Now $n_0=2$.

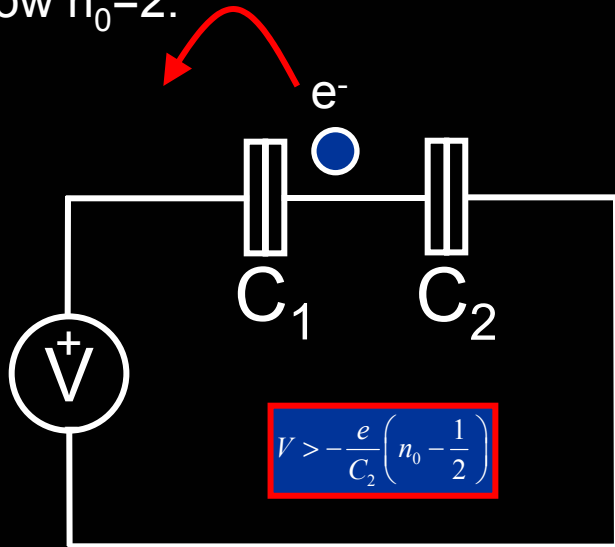

$$V > \frac{3e}{2C_2}$$

Coulomb staircase

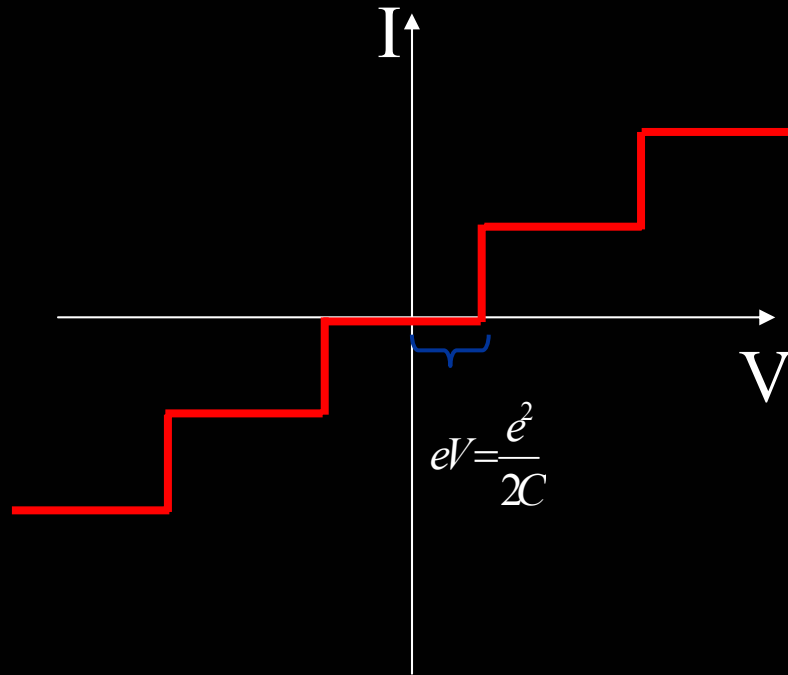
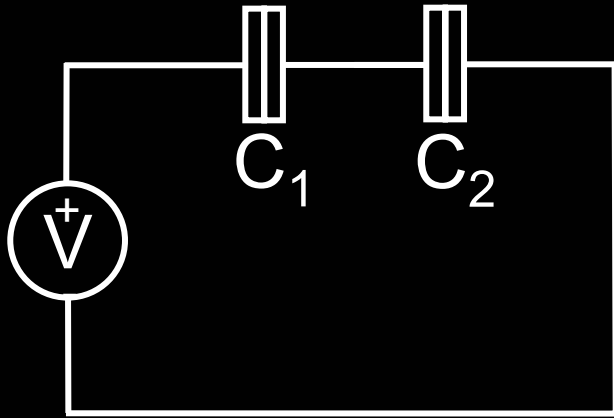

Overall slope is R_{tunnel} , which is *large*.