

# **Lasers and Photonics**

## **ECE275, Winter 2003**

### **Professor & Class Schedule**

**Peter Burke**

**e-mail:** [pburke@uci.edu](mailto:pburke@uci.edu)

Lect. M/W 2:00 – 3:20 pm  
HH 262

Office hours: 1 p.m. - 2 p.m. Mondays and  
Wednesdays  
Office: EG 2232

# Optical communications course sequence

ECE 275A (F): Optical Communications

ECE 275B (W): Lasers and Photonics

ECE 275C (S): Integrated and Fiber Optics

# Course description

**UCI Catalog:** Covers the fundamentals of lasers and applications, including Gaussian beam propagation, interaction of optical radiation with matters, and concepts of optical gain and feedback. Applications are drawn from diverse fields of optical communication, signal processing, and material diagnosis. Prerequisite: undergraduate course work in electromagnetic theory and atomic physics.

# My teaching philosophy:

1. You want to learn.
2. One of my jobs is to evaluate what you have learned (i.e. grade).
3. One of my jobs is to teach, with the aid of the textbook.

Why bother coming to class?

To ask questions! And, because I will tailor the class to your background. (Give background survey.)

# Textbooks

Required:

J.T. Verdeyen, *Laser Electronics*, 3<sup>rd</sup> ed., Prentice Hall, 1995

(Ordered 20 from bookstore? Let me know if we should order more.)

Optional: (On reserve at the library. Let me know if it is working out!)

Yariv, "Optical Electronics and Modern Communications". 1997

B. E. A. Saleh and M. C. Teich, "Fundamentals of Photonics", 1991. A thorough treatment of lasers and classical optics.

Mandel and Wolf, "Optical Coherence and Quantum Optics", 1998. A very deep, excellent treatment of quantum optics.

Govind P. Agrawal, "Fiber-Optic Communication Systems", 1996. An overview from the systems point of view. Some detail on individual component operations.

Eberly, "Lasers", 1988, an excellent text on classical laser operation.

Riazat, "Introduction to High-speed Electronics and Opto-electronics", 1996. (Not on reserve; the library does not own this one.)

# Grading

- Midterm 25%
- Final Project 25%
- Final exam 50%

# Course outline

- Lecture 1: Introduction
- Lecture 2: Classical review of electromagnetic waves (Maxwell's equations)
- Lecture 3: Fields in a box
- Lecture 4: Planck, atomic physics, Einstein A/B coefficients
- Lecture 5: Two level rate equations
- Lecture 6: Three level rate equations
- Lecture 7: Gain saturation, Fiber amplifiers
- Lecture 8: Laser oscillation
- Lecture 9: Laser output power
- Lecture 10: Time dependent oscillation
- Lecture 11: Example lasers
- Lecture 12: Band theory of solids
- Lecture 13: Optical properties of semiconductors
- Lecture 14: Semiconductor lasers
- Lecture 15: DBR, DFB semiconductor lasers

# Outline for today:

1. What is a laser?
2. How does it work?
3. What are some of the properties that I care about?
4. Reading for this lecture:  
Verdeyen chapter “0”

# LASERS:

*Light Amplification by Stimulated Emission of Radiation*

Step 1: Build a “cavity”:



Mirror



Mirror

# LASERS:

## *Light Amplification by Stimulated Emission of Radiation*

Step 1: Build a “cavity”:

Step 2: Insert a “gain medium”

(special atoms in liquid, solid, or gas)

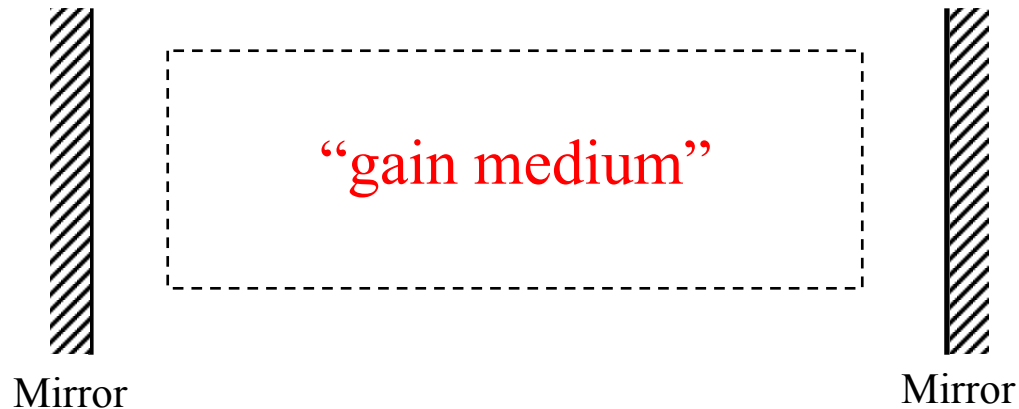

# LASERS:

## *Light Amplification by Stimulated Emission of Radiation*

Step 1: Build a “cavity”:

Step 2: Insert a “gain medium”

Step 3: Start it up! (How?)

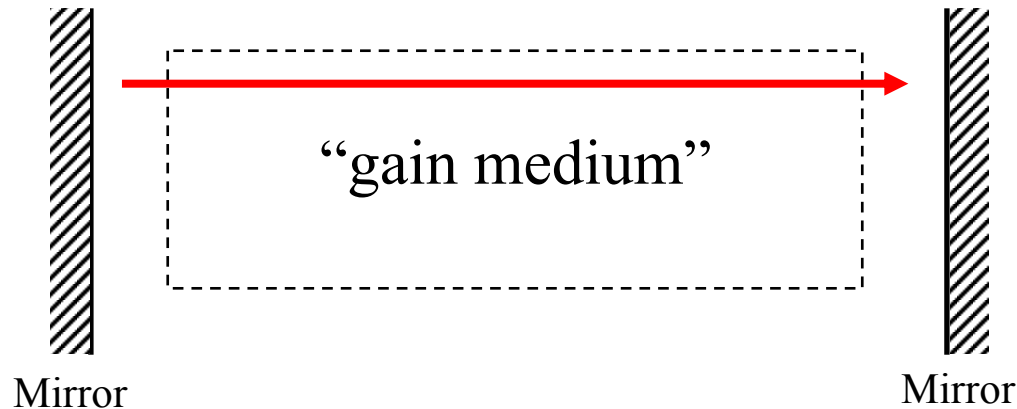

# LASERS:

## *Light Amplification by Stimulated Emission of Radiation*

Step 1: Build a “cavity”:

Step 2: Insert a “gain medium”

Step 3: Start it up! (How?)

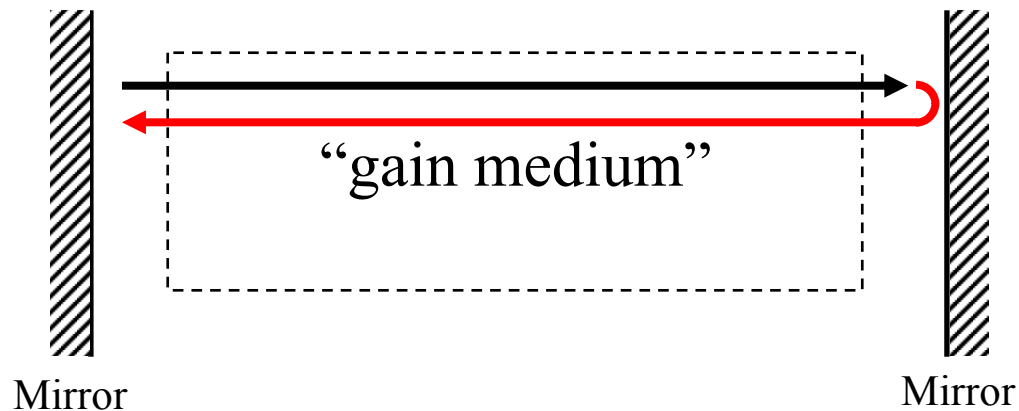

# LASERS:

## *Light Amplification by Stimulated Emission of Radiation*

Step 1: Build a “cavity”:

Step 2: Insert a “gain medium”

Step 3: Start it up! (How?)

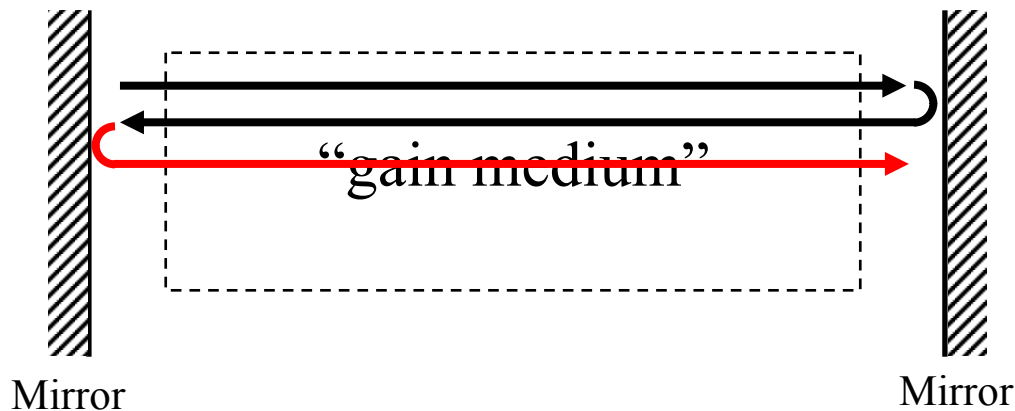

# LASERS:

## *Light Amplification by Stimulated Emission of Radiation*

Step 1: Build a “cavity”:

Step 2: Insert a “gain medium”

Step 3: Start it up! (How?)

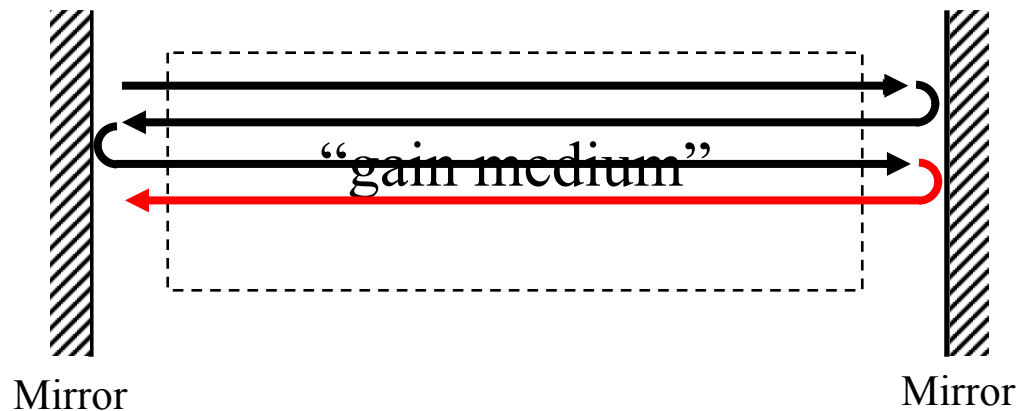

# LASERS:

## *Light Amplification by Stimulated Emission of Radiation*

Step 1: Build a “cavity”:

Step 2: Insert a “gain medium”

Step 3: Start it up! (How?)

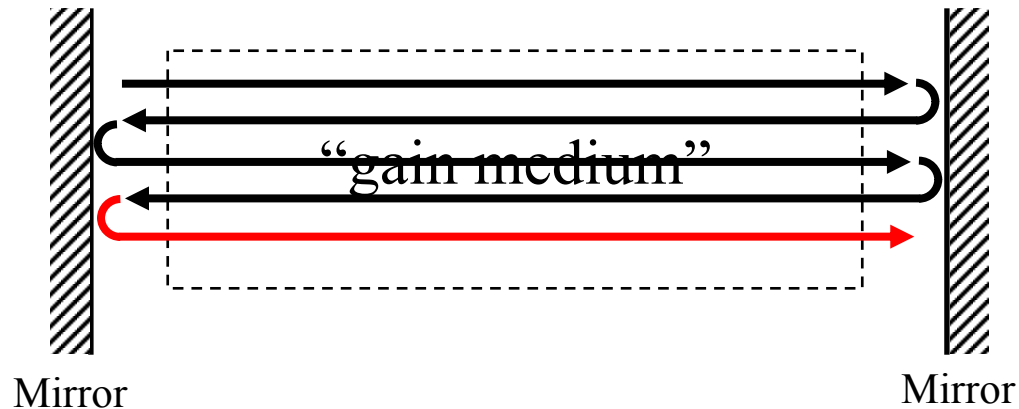

# LASERS:

## *Light Amplification by Stimulated Emission of Radiation*

Step 1: Build a “cavity”:

Step 2: Insert a “gain medium”

Step 3: Start it up! (How?)

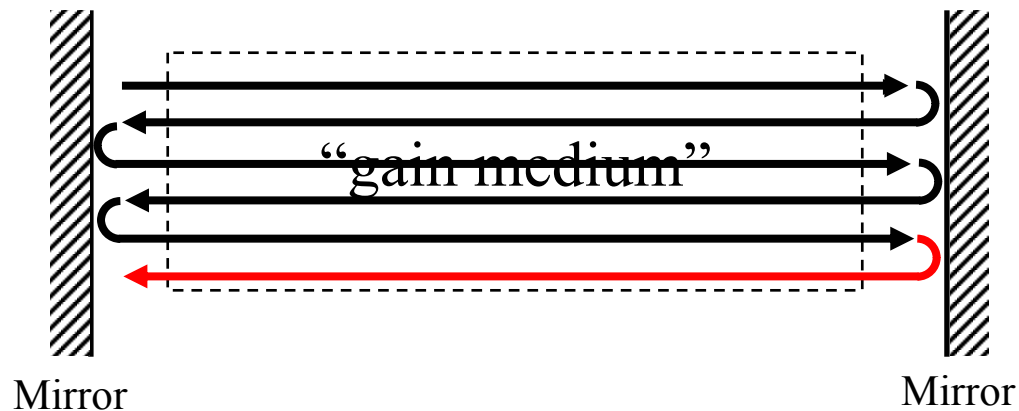

# LASERS:

## *Light Amplification by Stimulated Emission of Radiation*

Step 1: Build a “cavity”:

Step 2: Insert a “gain medium”

Step 3: Start it up! (How?)

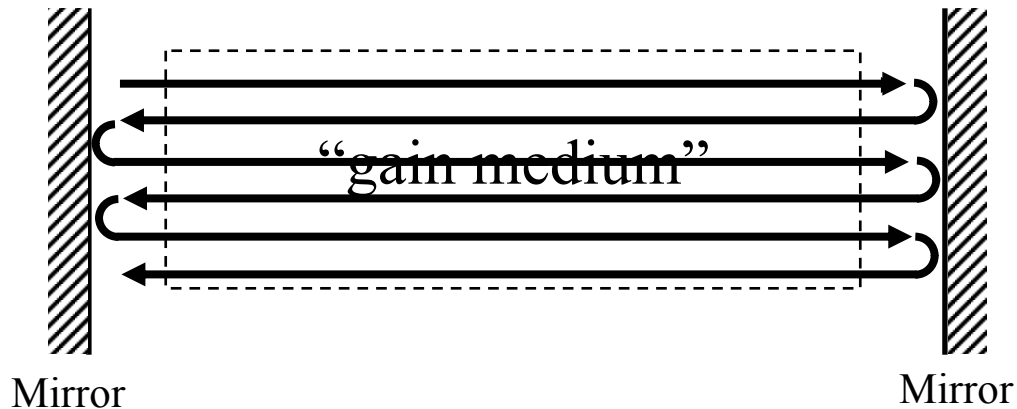

# Comments:

1. How long will intensity continue to increase?
2. What about loss at the mirror wall, and elsewhere?
3. How do we get the light out?
4. What if the mirrors are not aligned?
5. Where does the amplification energy come from?

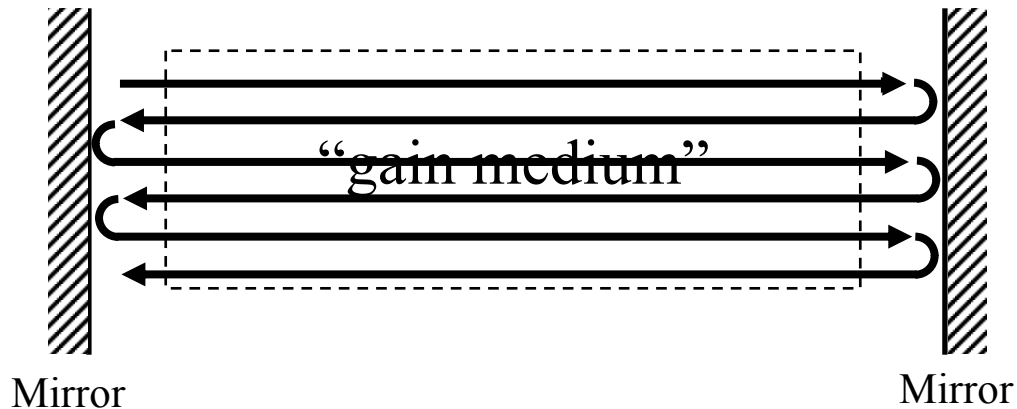

# Comments:

## 1. How long will intensity continue to increase?

Until gain saturates.

We will discuss physical reasons for this later in the course.

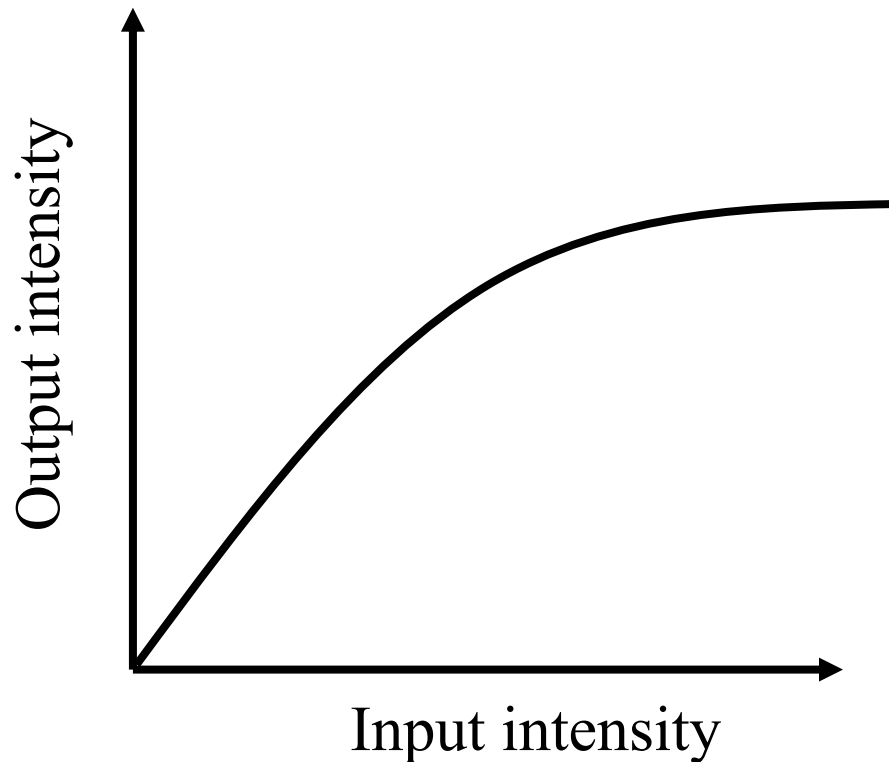

# Comments:

2. What about loss at the mirror wall, and elsewhere?

Each trip will have some loss (absorption, scattering), and some gain.

For the laser to work, we need

Net round trip gain  $> 1$

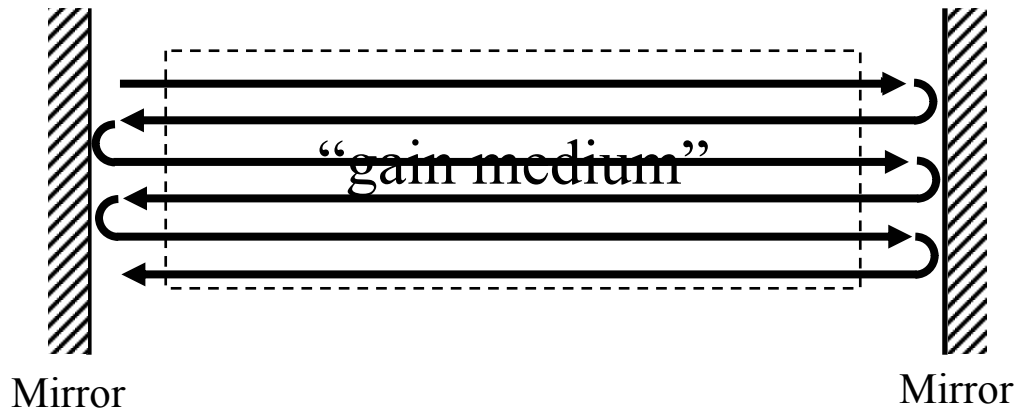

# Comments:

## 3. How do we get the light out?

Pinhole, or semi-transparent mirror.

We will discuss this quantitatively later.

(Any ideas how to make a semi-transparent mirror?)

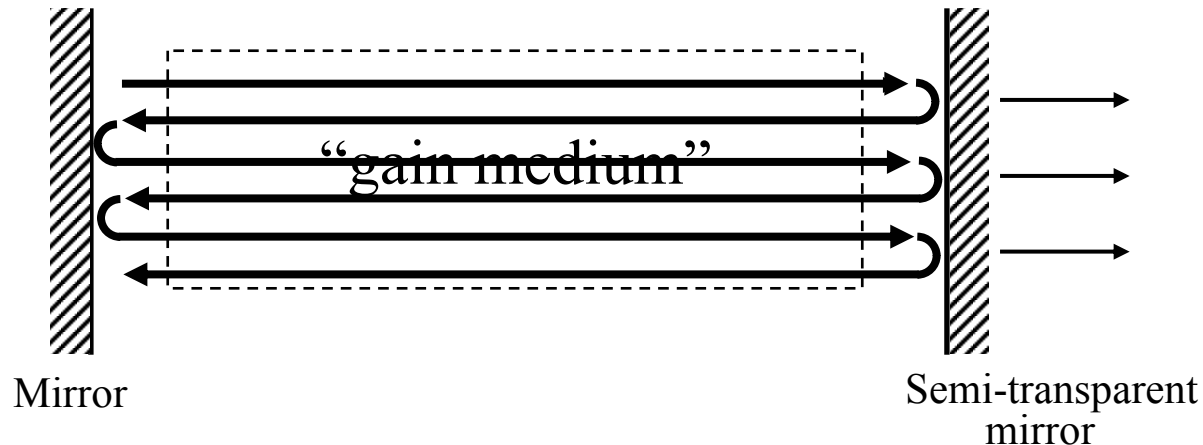

# Comments:

## 4. What if the mirrors are not aligned?

The beam will diverge.

Also, perfectly aligned beam will not stay in place, even if mirrors are perfectly aligned.

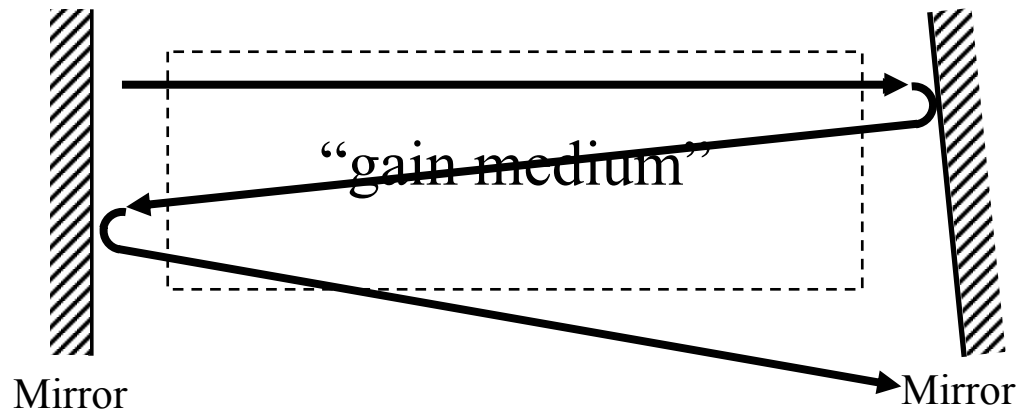

# Comments:

4. What if the mirrors are not aligned?

One solution: Curved mirrors

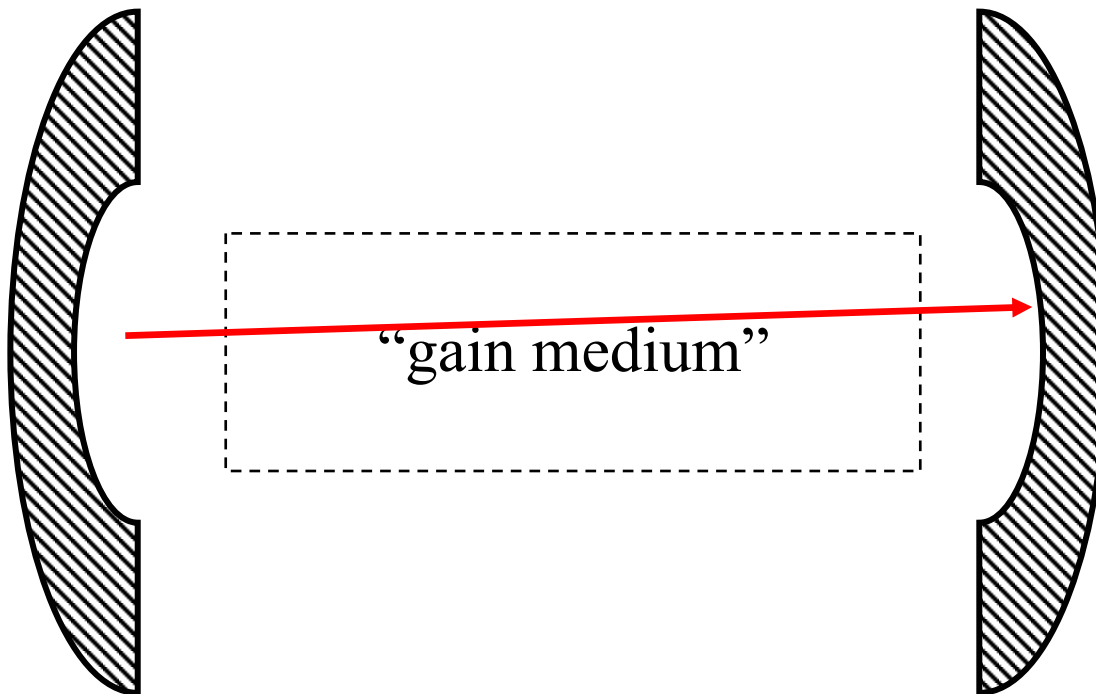

# Comments:

4. What if the mirrors are not aligned?

One solution: Curved mirrors

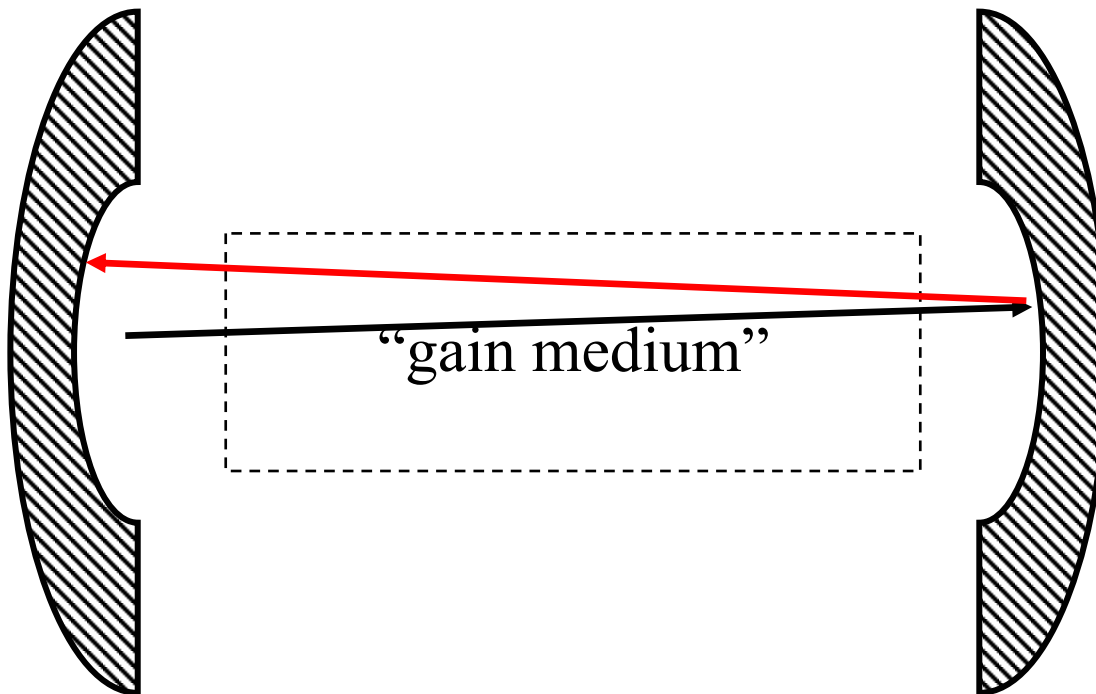

# Comments:

4. What if the mirrors are not aligned?

One solution: Curved mirrors

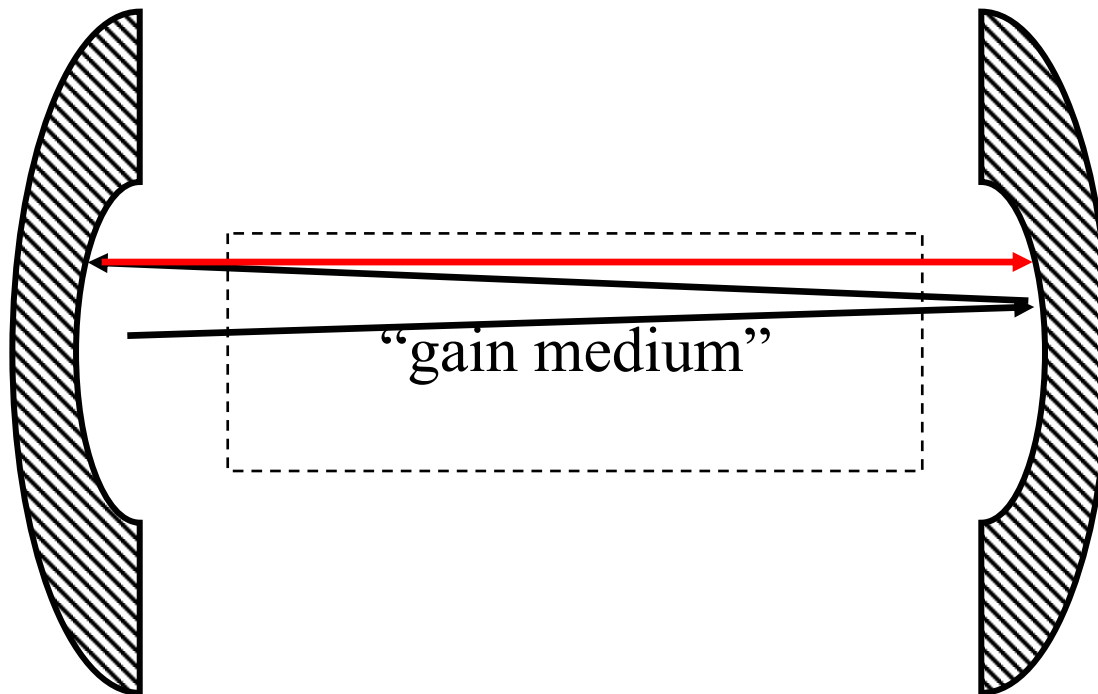

# Comments:

4. What if the mirrors are not aligned?

One solution: Curved mirrors

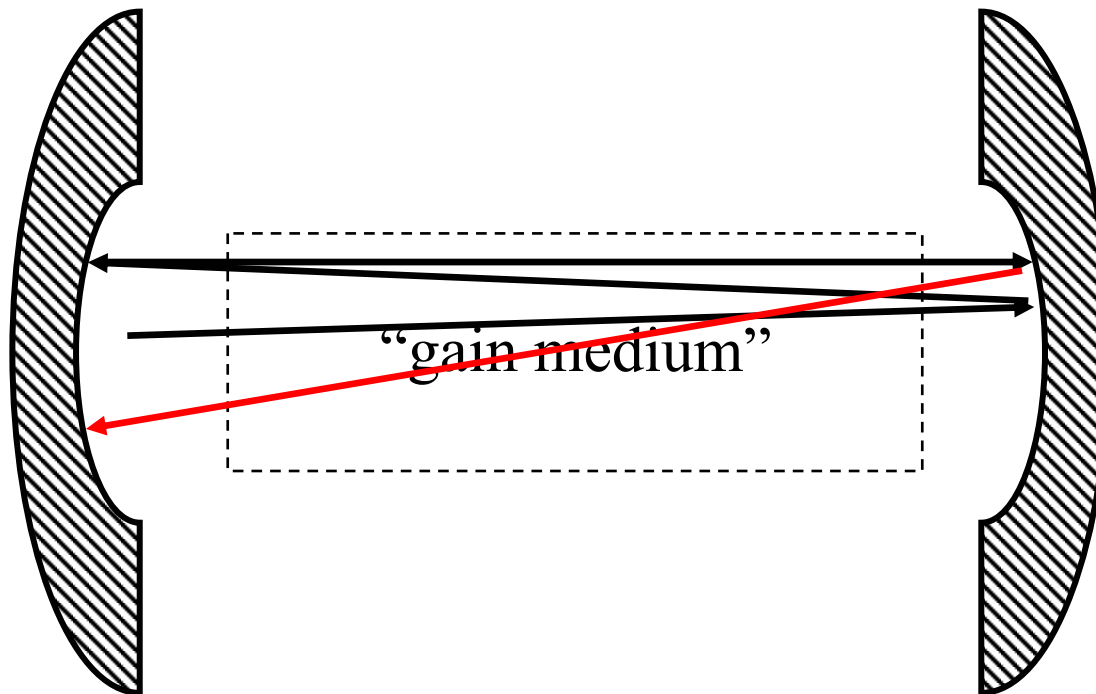

# Comments:

4. What if the mirrors are not aligned?

One solution: Curved mirrors

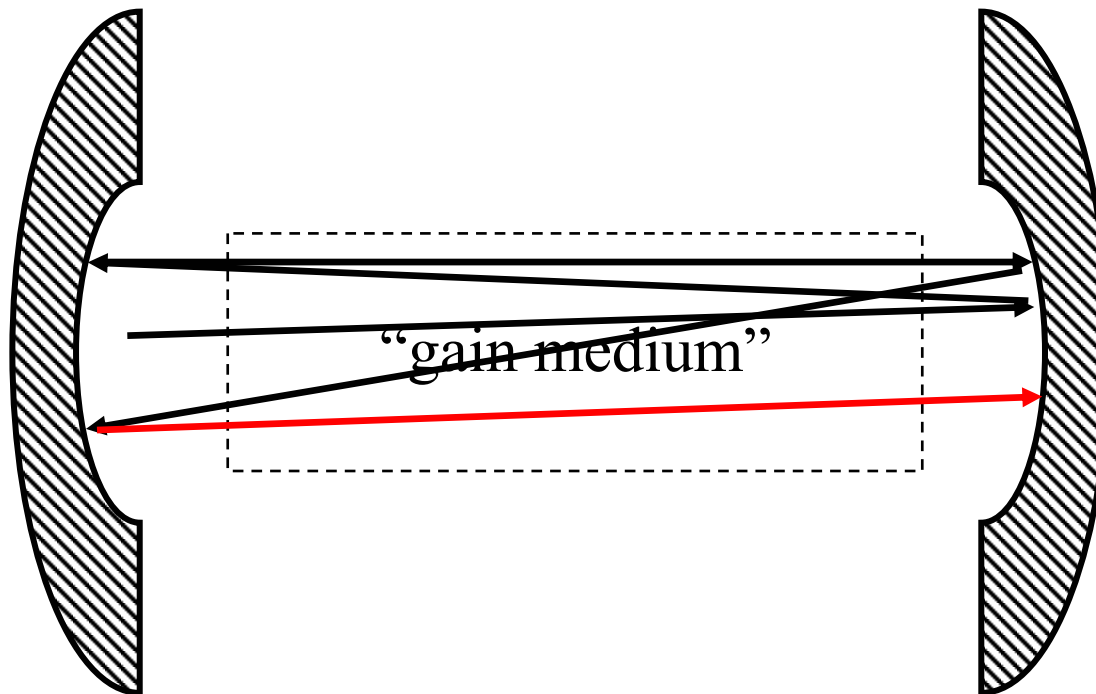

# Comments:

4. What if the mirrors are not aligned?

One solution: Curved mirrors

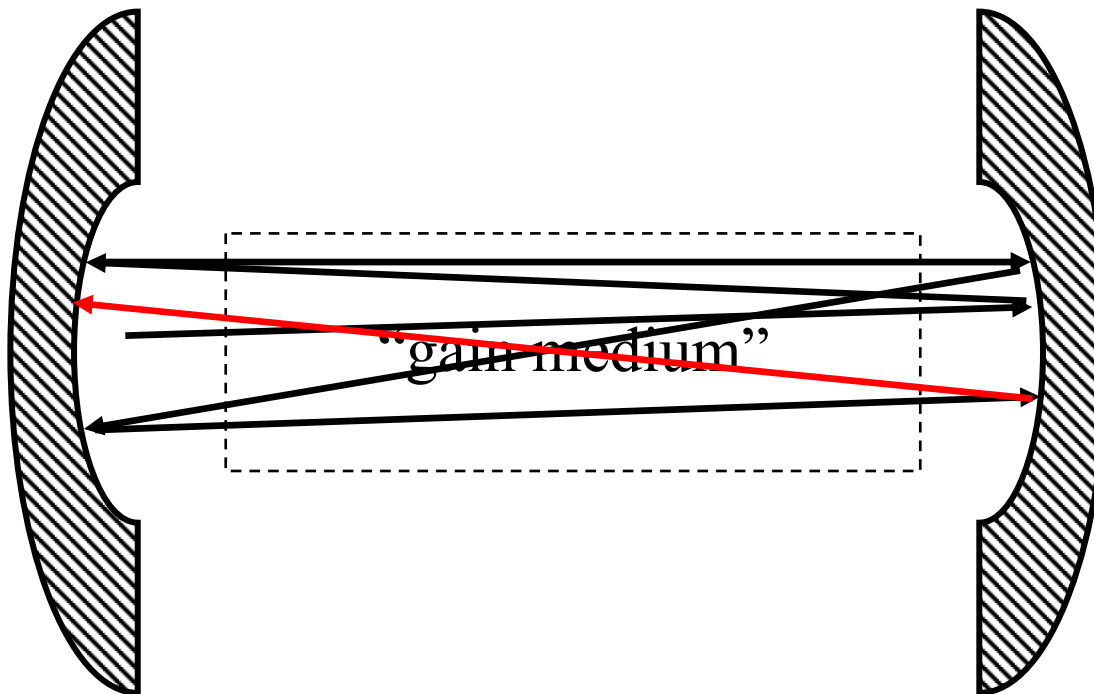

# Comments:

## 5. Where does the amplification energy come from?

We use a “pump” to bring energy into the gain medium.

Two ways to pump: electrically and optically.

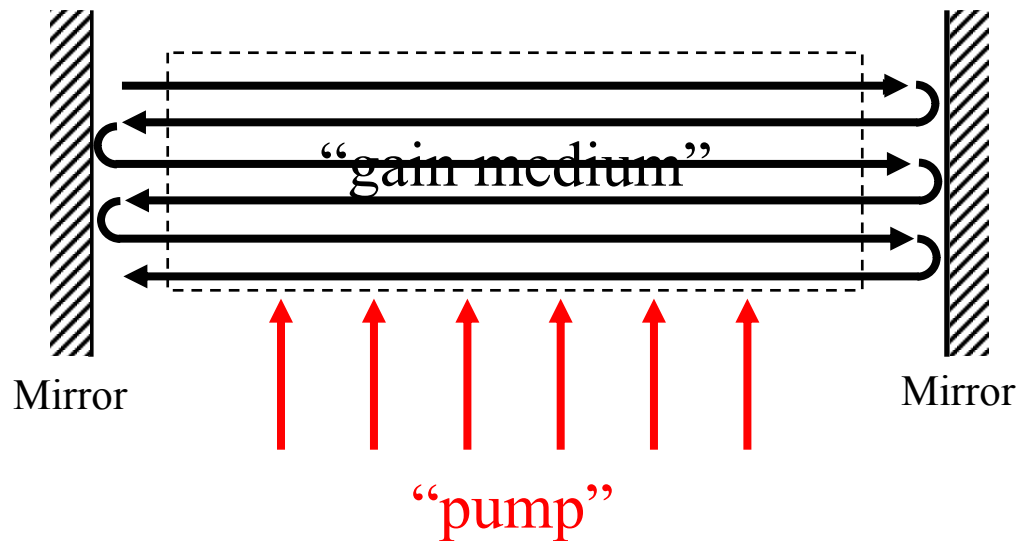

# Brief description of a photon:

“Particle of light”

Photon

$$E=h\nu$$

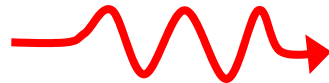

1 eV  
2.4 10<sup>14</sup> Hz  
1.25 μm  
502 cm<sup>-1</sup>

Planck's constant:  
 $h=6.6 \cdot 10^{-16}$  eV-s

$\lambda\nu=c$   
 $\lambda$ =wavelength  
 $\nu$ =frequency

Speed of light:  
 $c=3 \cdot 10^8$  m/s

Wavevector  
 $k=2\pi/\lambda$

# Brief quantum description of gain process:

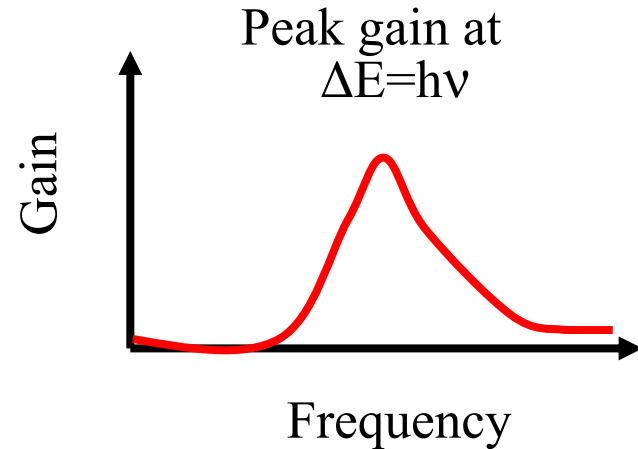
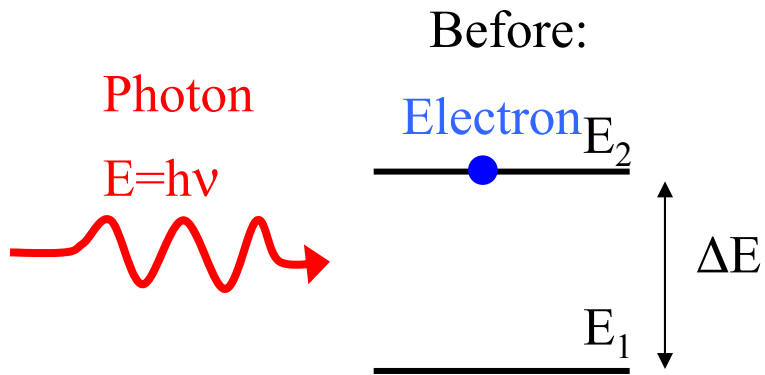

After:

First photon “stimulates”  
emission of second photon

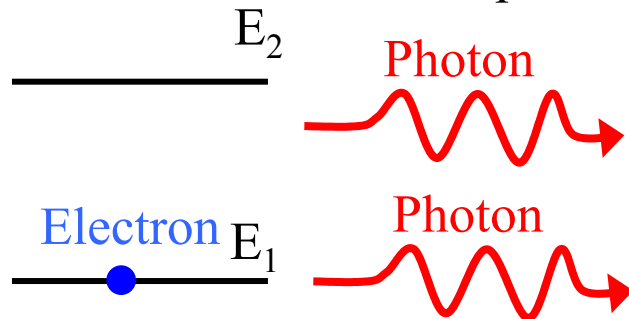

(We will discuss in  
detail in lecture 4.)

# Very important comments:

- Different atoms and molecules different gain  $\Delta E$ !
- Electrons in semiconductors can have widely tunable  $\Delta E$ !

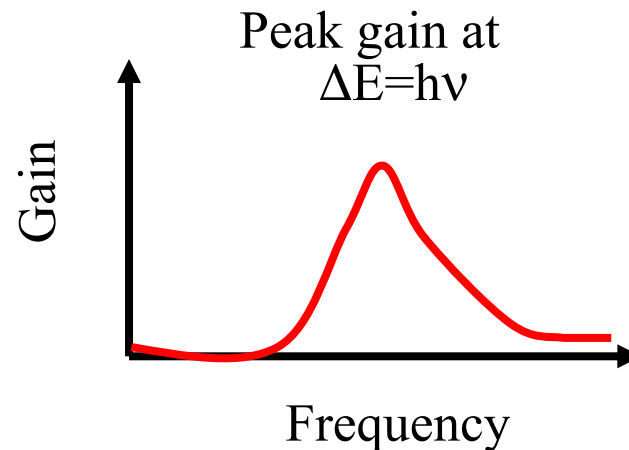

## Examples of gain media:

- Neon atoms in a gas (HeNe) 6328 Å
- Chromium atoms in Ruby solid host 6943 Å
- Neodymium atoms in glass/YAG solid host 1.06 μm
- Erbium atoms in glass fiber host 1.5 μm
- Molecular dyes in water or alcohol host 400-1000 Å
- Titanium atoms in a sapphire host 0.7-1.02 μm
- Argon ions in a argon gas 350 – 520 Å
- CO<sub>2</sub> gas 10 μm
- Electrons in semiconductors:
  - Al<sub>x</sub>Ga<sub>1-x</sub>As 0.7-0.9 μm
  - In<sub>x</sub>Ga<sub>1-x</sub>As<sub>1-y</sub>P<sub>y</sub> 1.1-1.6 μm
- OH gas molecules ~ 30 cm

## A bit of history:

- $10^9$  yr. B.C. First lasers were OH molecules, 1.6 GHz, in the cosmos, invented by mother nature. They were “masers”:  
*Microwave Amplification by Stimulated Emission of Radiation.*
- 1954: First manmade maser, Townes Gordon Zeiger, 24 GHz ammonia ( $\text{NH}_3$ )
- 1960 Ruby laser, Maiman, Hughes Research Laboratory
- 1960 HeNe laser (first cw), Javan et al, Bell Labs

# What are some of the properties of lasers that I care about?

- Output is close to a sine wave (linewidths down to 1 Hz can be achieved)
- Output is *coherent*, i.e. phase information is preserved

## A1112 High-Power 1550 nm DFB Source Lasers

---



### Description

The A1112 1550 nm DFB laser modules are high-power devices in a 14-pin butterfly package with a thermoelectric cooler and monitor photodiode. The lasers are designed to be used in conjunction with commercially available external modulators for high-performance analog and digital applications. Agere Systems Inc. offers modules with 30 mW or 40 mW output power coupled into polarization-preserving fiber. The A1112 operates with positive or negative bias.

### Features

- High fiber-coupled power, 30 mW and 40 mW
- Narrow linewidth, <3 MHz
- Low relative intensity noise, < -162 dB/Hz
- Coupled to polarization-preserving (PANDA-type fiber)

### Applications

- Externally modulated CATV transmitters
- Externally modulated analog and digital communication links

## Absolute Maximum Ratings

Stresses in excess of the absolute maximum ratings can cause permanent damage to the device. These are absolute stress ratings only. Functional operation of the device is not implied at these or any other conditions in excess of those given in the operational sections of the data sheet. Exposure to absolute maximum ratings for extended periods can adversely affect device reliability.

Parameter	Symbol	Min	Max	Unit
Operating Case Temperature Range	T <sub>C</sub>	-20	65	°C
Storage Temperature Range	T <sub>stg</sub>	-40	70	°C
Forward Current (Laser)	I <sub>F</sub>	—	275	mA
A1112PB, A1112NB		—	400	mA
A1112PC, A1112NC				
Reverse Voltage (Laser)	V <sub>R</sub>	—	2.0	V
Photodiode Reverse Voltage	V <sub>RPD</sub>	—	10	V
TEC Voltage	V <sub>TEC</sub>	—	2.0	V
TEC Current	I <sub>TEC</sub>	—	1.8	A
Cooling		—	1.5	A
Heating				

## Electrical/Optical Characteristics

Table 1. Optical Characteristics (25 °C Case Temperature)

Parameter	Symbol	Conditions	Min	Max	Unit
Optical Output Power	P <sub>O</sub>	—	30	—	mW
A1112PB, A1112NB		—	40	—	mW
A1112PC, A1112NC					
Center Wavelength	$\lambda_C$	I <sub>OP</sub>	1540	1560	nm
Linewidth (FWHM)	$\Delta\nu$	I <sub>OP</sub>	—	3	MHz
Side Mode Suppression Ratio	SMSR	I <sub>OP</sub>	30	—	dB
Relative Intensity Noise	RIN	I <sub>OP</sub> , 40 MHz to 860 MHz	—	-162	dBc/Hz
Operating Current	I <sub>OP</sub>	—	—	250/350	mA
Threshold Current	I <sub>TH</sub>	—	—	35/40	mA
Forward Voltage	V <sub>F</sub>	—	—	2.5/3.0	V
Optical Isolation	—	-20 °C to +65 °C	30	—	dB
Polarization Extinction Ratio	T <sub>E</sub> /T <sub>M</sub>	From fiber end, I <sub>OP</sub>	20	—	dB
Reverse Voltage	V <sub>R</sub>	—	—	2.0	V

Table 2. Electrical Characteristics

Parameter	Symbol	Condition	Min	Max	Unit
Monitor Photodiode Reverse Voltage	V <sub>RMPD</sub>	I <sub>OP</sub>	—	10	V
Monitor Photodiode Current	I <sub>MPD</sub>	—	40	2000	μA
TEC Current	I <sub>TEC</sub>	$\Delta T = 40\text{ °C}$	—	1.8	A
TEC Voltage	V <sub>TEC</sub>	$\Delta T = 40\text{ °C}$	—	2.2	V
Thermistor Resistance	R <sub>TH</sub>	25 °C	9.0	11.0	kΩ

Electrical/Optical Characteristics (continued)

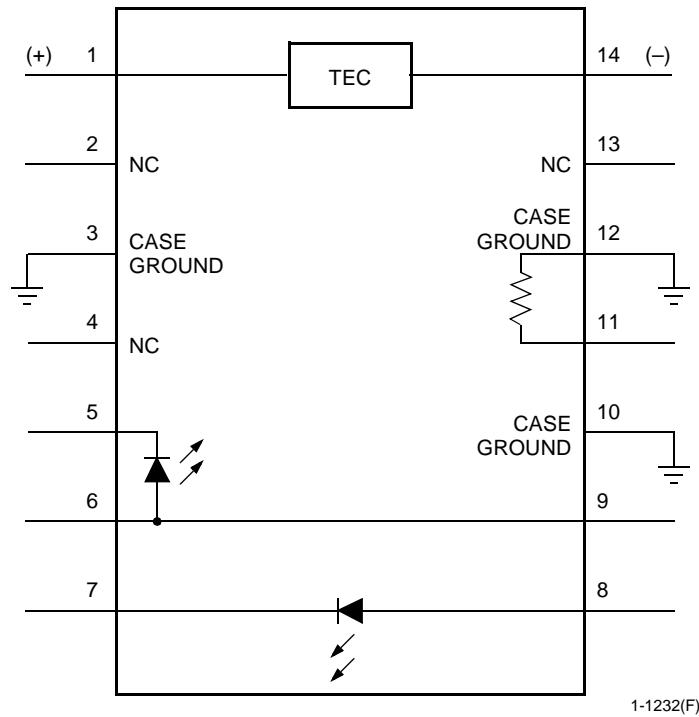

1-1232(F)

Figure 1. A1112 Laser Positive Bias Ciicuit Schematic

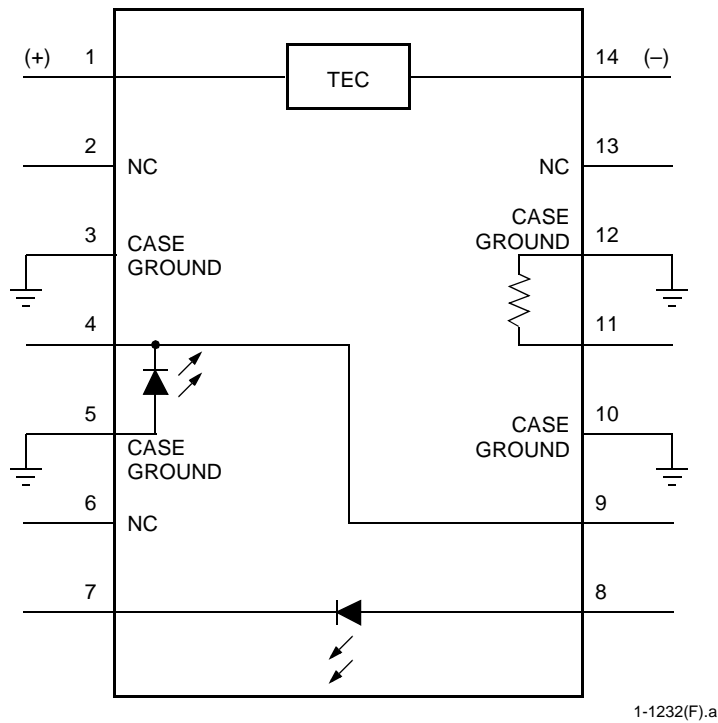

1-1232(F).a

Figure 2. A1112 Laser Negative Bias Ciicuit Schematic

### Outline Diagram

Dimensions are in inches and (millimeters).

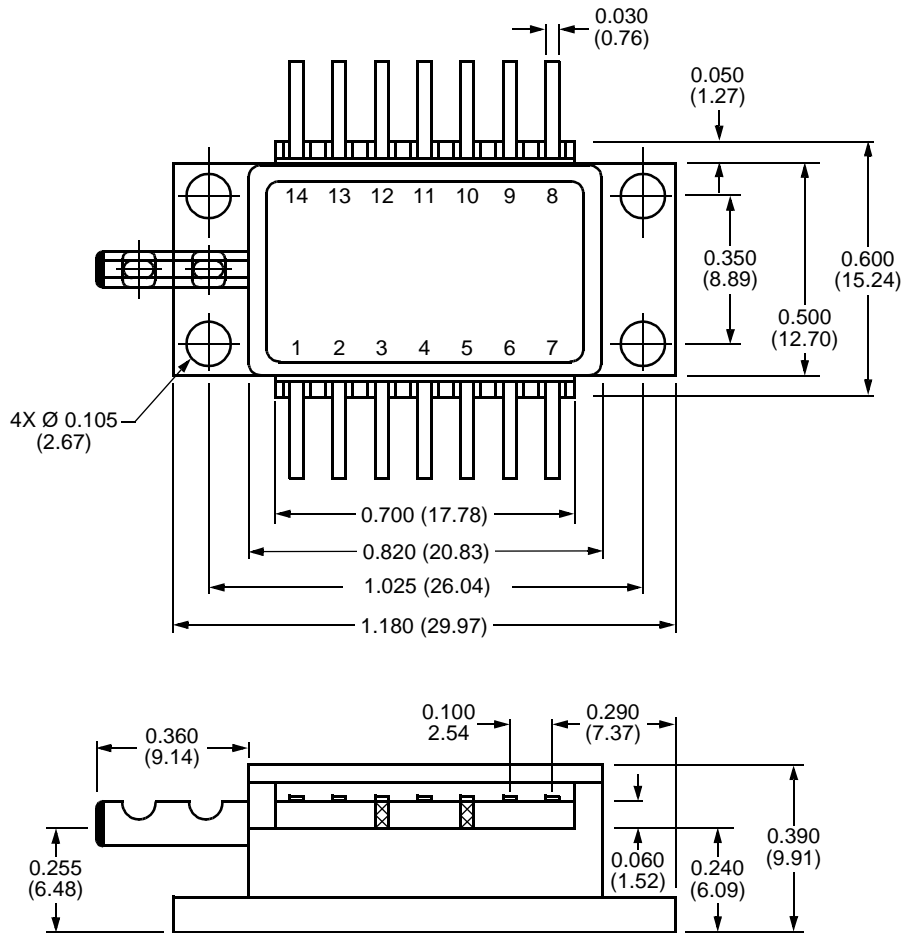

1-1177(F)

### Pin Information

Table 3. Pin Descriptions

Pin No.	A1112 (Positive Bias)	A1112 (Negative Bias)	Pin No.	A1112 (Positive Bias)	A1112 (Negative Bias)
1	TE Cooler (+)	TE Cooler (+)	8	Photodiode Anode	Photodiode Anode
2	NC	NC	9	Laser Anode	Laser Cathode
3	Case Ground	Case Ground	10	Case Ground	Case Ground
4	NC	Laser Cathode	11	Thermistor	Thermistor
5	Laser Cathode, Case Ground	Laser Anode, Case Ground	12	Case Ground	Case Ground
6	Laser Anode	NC	13	NC	NC
7	Photodiode Cathode	Photodiode Cathode	14	TE Cooler (-)	TE Cooler (-)

## Laser Safety Information

### Class IIIb Laser Product

FDA/CDRH Class IIIb laser product. All versions are Class IIIb laser products per CDRH, 21 CFR 1040 Laser Safety requirements. All versions are Class 3B laser products per *IEC*<sup>1</sup> 60825-1:1993. The device has been classified with the FDA under an accession number to be determined.

This product complies with 21 CFR 1040.10 and 1040.11.

*Fujikura*<sup>2</sup> PANDA single-mode fiber pigtail, 1 m—2 m; FC/APC connector, nonaligned

Wavelength = 1.5  $\mu\text{m}$

Maximum power = 60 mW

Because of size constraints, laser safety labeling (including an FDA Class IIIb label) is not affixed to the module but attached to the outside of the shipping carton.

Product is not shipped with power supply.

**Caution: Use of controls, adjustments, and procedures other than those specified herein may result in hazardous laser radiation exposure.**

1. *IEC* is a registered trademark of The International Electrotechnical Commission.

2. *Fujikura* is a registered trademark of Fujikura LTD.

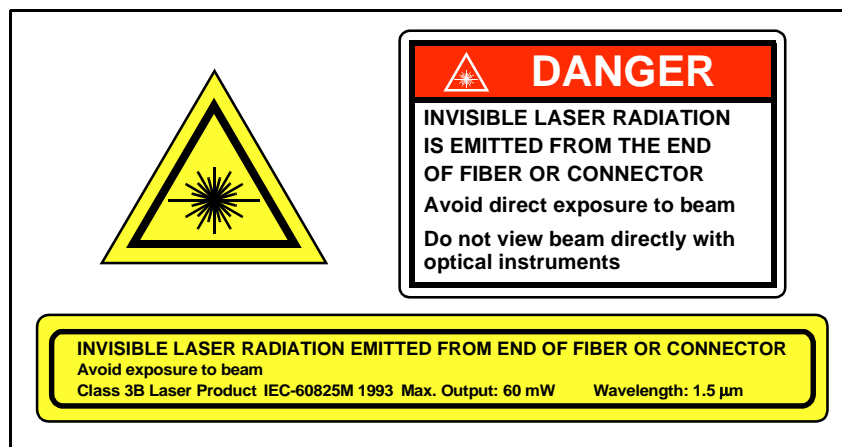

## Ordering Information

Table 4. Ordering Information<sup>1</sup>

Device Code	Output Power/Laser Bias	Fiber/Connector	Comcode
A1112PB	30 mW/ Positive Laser Bias	<i>Fujikura</i> PANDA/ FC/APC nonaligned	108846536
A1112PC	40 mW/ Positive Laser Bias		108846544
A1112NB	30 mW/ Negative Laser Bias		108846510
A1112NC	40 mW/ Negative Laser Bias		108846528

1. For additional ordering information, please contact an account manager at Opto West, Agere Systems, 1-800-362-3891 (for sales staff, please press option 2).

For additional information, contact your Agere Systems Account Manager or the following:

INTERNET: <http://www.agere.com>

E-MAIL: [docmaster@micro.lucnet.com](mailto:docmaster@micro.lucnet.com)

N. AMERICA: Agere Systems Inc., 555 Union Boulevard, Room 30L-15P-BA, Allentown, PA 18109-3286  
1-800-372-2447, FAX 610-712-4106 (In CANADA: 1-800-553-2448, FAX 610-712-4106)

ASIA PACIFIC: Agere Systems Singapore Pte. Ltd., 77 Science Park Drive, #03-18 Cintech III, Singapore 118256  
Tel. (65) 778 8833, FAX (65) 777 7495

CHINA: Agere Systems (Shanghai) Co., Ltd., 33/F Jin Mao Tower, 88 Century Boulevard Pudong, Shanghai 200121 PRC  
Tel. (86) 21 50471212, FAX (86) 21 50472266

JAPAN: Agere Systems Japan Ltd., 7-18, Higashi-Gotanda 2-chome, Shinagawa-ku, Tokyo 141, Japan  
Tel. (81) 3 5421 1600, FAX (81) 3 5421 1700

EUROPE: Data Requests: DATALINE: Tel. (44) 7000 582 368, FAX (44) 1189 328 148  
Technical Inquiries: OPTOELECTRONICS MARKETING: (44) 1344 865 900 (Ascot UK)

Agere Systems Inc. reserves the right to make changes to the product(s) or information contained herein without notice. No liability is assumed as a result of their use or application.